

# BZL Ergo Features and Benefits

**Swan Necks**

- High temperature resistant insulation materials reducing the risk of shorting
- Durable and Robust

**Handles**  
**Maximises user comfort**

- Designed for balance, lightness and strength
- Enhances wire feeding performance
- Screwless design for rapid servicing

**Cable Supports**  
**Improved Wire Feed**

- The perfect balance of freedom of movement and progressive support to the power cable is achieved

**Contact Tips**

- Manufactured using a harder and higher conductivity copper alloy than the OEM

**Hanger Hooks**  
**Easy to store**

- Less prone to damage
- Encourages an efficient and tidy workspace

**Knuckle Joint**  
**Improved Manoeuvrability**

- Small movements of the handle and neck are possible independently of the cable assembly

**Nozzles**  
**Maximises Performance**

- Maximum wall thickness gives longevity and superior performance
- Manufactured to the same specifications as the OEM

**Hydroflex™ Cable Systems**

- Liquid cooled cable systems use high temperature resistant rubber cables which ensure leak free terminations

**Hyperflex™ Cable Systems**

- Air cooled cable assemblies offer outstanding flexibility and the highest heat and abrasion resistance of any known cable
- Cable end crimp systems ensure maximum conductivity whilst the outer jacket is constructed from cross linked polymers providing a tear proof jacket and a burn threshold of 375°C

**Machine End Systems**

- Extra length cable support systems
- Smooth and consistent wire feed
- Simple snap fits

**Gun Plug Bodies**

- Spring loaded pins
- Guaranteed gas seals

## Quality Standards

All torches are rigorously tested using computerised and automated test equipment at the design stage through to production.  
 All our components pass rigorous quality control checks prior to assembly.  
 All torches are designed to be tough and damage resistant and comply with EN60974-7.



# BZL Everyday Features and Benefits

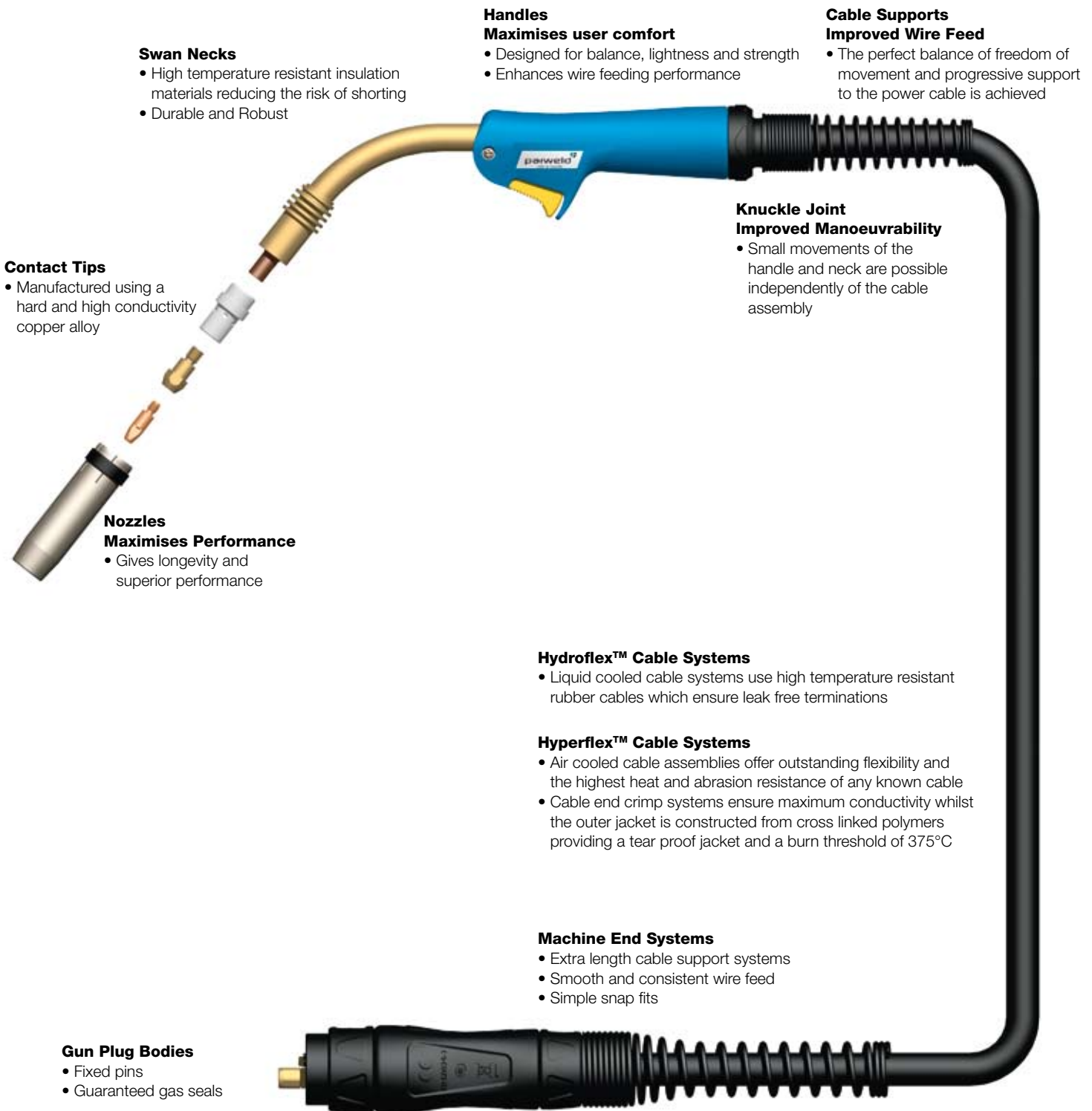

## Quality Standards

All torches are rigorously tested using computerised and automated test equipment at the design stage through to production.

All our components pass rigorous quality control checks prior to assembly.

All torches are designed to be tough and damage resistant and comply with EN60974-7.



# BZL Nozzles

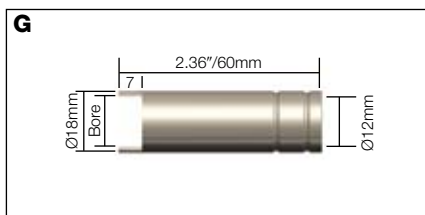
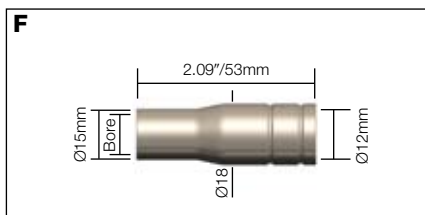
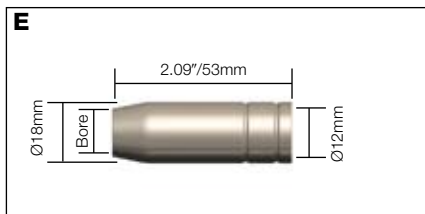
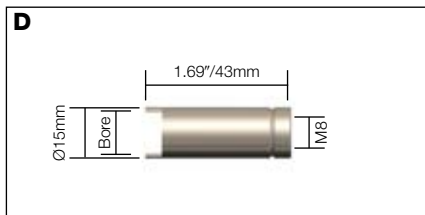
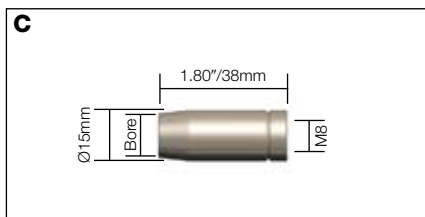
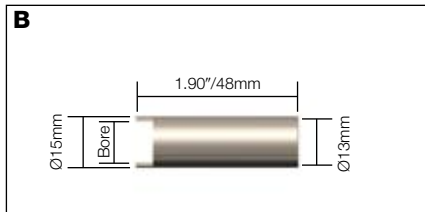
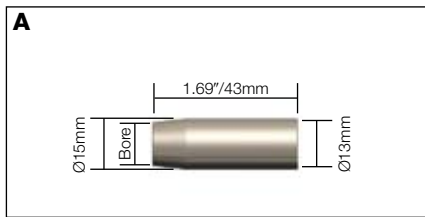

Nozzles				
Stock Code	Description	Bore	Bore	Model
<b>A</b> B1430-P	Conical Nozzle - Push On	7/16"	11mm	SB120A

Stock Code	Description	Bore	Bore	Model
<b>B</b> B1430-S	Spot Welding Nozzle - Push On	1/2"	13mm	SB120A

Stock Code	Description	Bore	Bore	Model
<b>C</b> B1430	Conical Nozzle - Screw On	7/16"	11mm	SB120A

Stock Code	Description	Bore	Bore	Model
<b>D</b> B1431	Spot Welding Nozzle - Screw On	1/2"	13mm	SB120A

Stock Code	Description	Bore	Bore	Model
<b>E</b> B1529	Cylindrical Nozzle	5/8"	16mm	SB140A, SB150A
B1530	Conical Nozzle	15/32"	12mm	SB140A, SB150A
ECO1530	Everyday Conical Nozzle	15/32"	12mm	ECR150A
B1531	Tapered Nozzle	7/16"	11mm	SB140A, SB150A

Stock Code	Description	Bore	Bore	Model
<b>F</b> B1532	Bottle Nozzle	1/2"	13mm	SB140A, SB150A

Stock Code	Description	Bore	Bore	Model
<b>G</b> B1533	Spot Welding Nozzle	5/8"	16mm	SB140A, SB150A

Stock Code	Description	Bore	Bore	Model
<b>H</b> B2415	Cylindrical Nozzle	11/16"	17mm	SB230A, SB240A, SB240W
B2416	Conical Nozzle	1/2"	13mm	SB230A, SB240A, SB240W
B2417	Tapered Nozzle	3/8"	10mm	SB230A, SB240A, SB240W

# BZL Nozzles

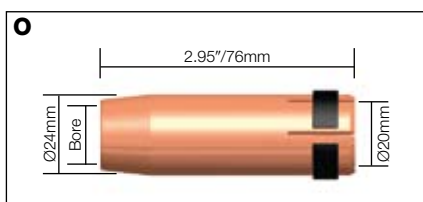
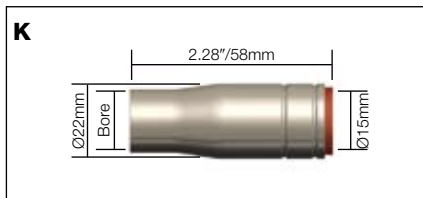
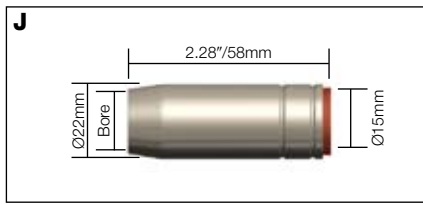

Nozzles					
Stock Code	Description	Bore	Bore	Model	
<b>J</b> B2507	Cylindrical Nozzle	5/7"	18mm	SB250A, SB350W	
B2508	Conical Nozzle	19/32"	15mm	SB250A, SB350W	
B2509	Tapered Nozzle	15/32"	12mm	SB250A, SB350W	
ECO2507	Everyday Cylindrical Nozzle	5/7"	18mm	ECR250A	
ECO2508	Everyday Conical Nozzle	19/32"	15mm	ECR250A	
ECO2509	Everyday Tapered Nozzle	15/32"	12mm	ECR250A	

Stock Code	Description	Bore	Bore	Model
<b>K</b> B2510	Bottle Nozzle	19/32"	15mm	SB250A, SB350W

Stock Code	Description	Bore	Bore	Model
<b>L</b> B2511	Spot Welding Nozzle	5/7"	18mm	SB250A, SB350W

Stock Code	Description	Bore	Bore	Model
<b>M</b> B3615	Cylindrical Nozzle	3/4"	19mm	SB360A
B3616	Conical Nozzle	5/8"	16mm	SB360A
B3617	Tapered Nozzle	15/32"	12mm	SB360A
ECO3615	Everyday Cylindrical Nozzle	3/4"	19mm	ECR360A
ECO3616	Everyday Conical Nozzle	5/8"	16mm	ECR360A
ECO3617	Everyday Tapered Nozzle	15/32"	12mm	ECR360A

Stock Code	Description	Bore	Bore	Model
<b>N</b> B4017	Conical Nozzle	5/7"	18mm	SB400A

Stock Code	Description	Bore	Bore	Model
<b>O</b> B5027	Cylindrical Nozzle	3/4"	19mm	SB380A-501W
B5028	Conical Nozzle	5/8"	16mm	SB380A-501W
B5029	Tapered Nozzle	9/16"	14mm	SB380A-501W
ECO5027	Everyday Cylindrical Nozzle	3/4"	19mm	ECR501W
ECO5028	Everyday Conical Nozzle	5/8"	16mm	ECR501W
ECO5029	Everyday Tapered Nozzle	9/16"	14mm	ECR501W

Stock Code	Description	Bore	Bore	Model
<b>P</b> B5028HD	Heavy Duty Conical Nozzle	5/8"	16mm	SB380A, SB401W, SB501W

Stock Code	Description	Bore	Bore	Model
<b>Q</b> B6004	Conical Nozzle	25/32"	20mm	SB610A, SB610W
B6005	Cylindrical Nozzle	29/32"	23mm	SB610A, SB610W

# BZL Contact Tips

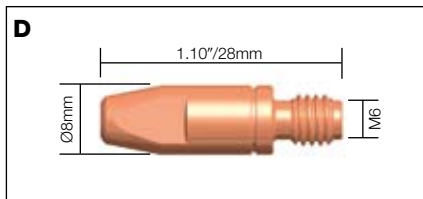
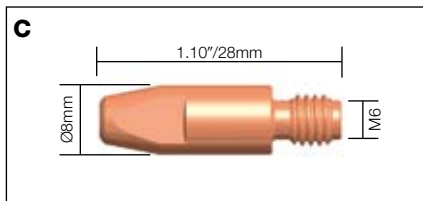
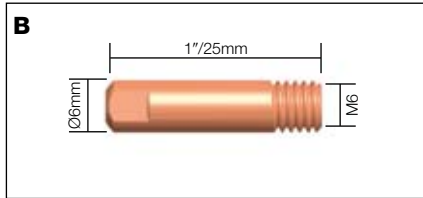
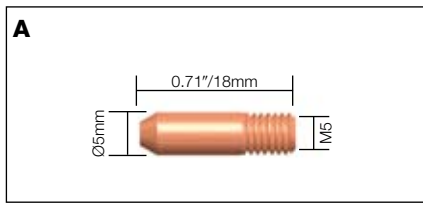

Tips						
Stock Code	Description	Wire Size	Wire Size	Material	Model	
<b>A</b> B1427-06	Contact Tip	.023"	0.6mm	Ecu	SB120A	
B1427-08	Contact Tip	.030"	0.8mm	Ecu	SB120A	
B1427-10	Contact Tip	.040"	1.0mm	Ecu	SB120A	

Stock Code	Description	Wire Size	Wire Size	Material	Model	
<b>B</b> B1527-06	Contact Tip	.023"	0.6mm	Ecu	SB140A, SB150A	
ECO1527-06	Everyday Contact Tip	.023"	0.6mm	Ecu	ECR150A	
B1527-08	Contact Tip	.030"	0.8mm	Ecu	SB140A, SB150A	
ECO1527-08	Everyday Contact Tip	.030"	0.8mm	Ecu	ECR150A	
B1527-09	Contact Tip	.035"	0.9mm	Ecu	SB140A, SB150A	
B1527-10	Contact Tip	.040"	1.0mm	Ecu	SB140A, SB150A	
B1527-12	Contact Tip	.045"	1.2mm	Ecu	SB140A, SB150A	

Stock Code	Description	Wire Size	Wire Size	Material	Model	
<b>C</b> B2504-06	Contact Tip	.023"	0.6mm	Ecu	SB230A-350W	
B2504-08	Contact Tip	.030"	0.8mm	Ecu	SB230A-350W	
ECO2504-08	Everyday Contact Tip	.030"	0.8mm	Ecu	ECR250A	
B2504-09	Contact Tip	.035"	0.9mm	Ecu	SB230A-350W	
B2504-10	Contact Tip	.040"	1.0mm	Ecu	SB230A-350W	
ECO2504-10	Everyday Contact Tip	.040"	1.0mm	Ecu	ECR250A	
B2504-12	Contact Tip	.045"	1.2mm	Ecu	SB230A-350W	
ECO2504-12	Everyday Contact Tip	.045"	1.2mm	Ecu	ECR250A	
B2504-14	Contact Tip	.055"	1.4mm	Ecu	SB230A-350W	
B2504-16	Contact Tip	1/16"	1.6mm	Ecu	SB230A-350W	
B2504-08CR	Contact Tip, Cr Plated	.030"	0.8mm	Ecu	SB230A-350W	
B2504-10CR	Contact Tip, Cr Plated	.040"	1.0mm	Ecu	SB230A-350W	
B2504-12CR	Contact Tip, Cr Plated	.045"	1.2mm	Ecu	SB230A-350W	
B2504-10A	Contact Tip, Ali Wire	.040"	1.0mm	Ecu	SB230A-350W	
B2504-12A	Contact Tip, Ali Wire	.045"	1.2mm	Ecu	SB230A-350W	
B2504-16A	Contact Tip, Ali Wire	1/16"	1.6mm	Ecu	SB230A-350W	

Stock Code	Description	Wire Size	Wire Size	Material	Model	
<b>D</b> B2505-08	Contact Tip	.030"	0.8mm	CuCrZr	SB230A-350W	
ECO2505-08	Everyday Contact Tip	.030"	0.8mm	CuCrZr	SB230A-350W	
B2505-09	Contact Tip	.035"	0.9mm	CuCrZr	SB230A-350W	
B2505-10	Contact Tip	.040"	1.0mm	CuCrZr	SB230A-350W	
ECO2505-10	Everyday Contact Tip	.040"	1.0mm	CuCrZr	SB250A	
B2505-12	Contact Tip	.045"	1.2mm	CuCrZr	SB230A-350W	
ECO2505-12	Everyday Contact Tip	.045"	1.2mm	CuCrZr	SB250A	
B2505-16	Contact Tip	1/16"	1.6mm	CuCrZr	SB230A-350W	

## Roll Marking

All Parweld consumables (except Everyday) are roll marked to enable you to identify genuine Parweld product.

# BZL Contact Tips/Tip Adaptors

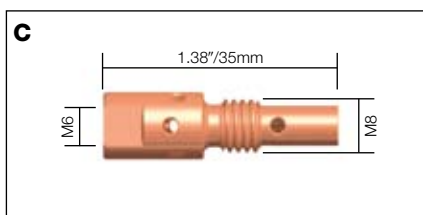
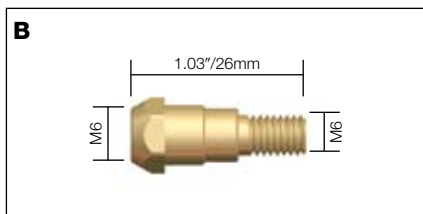
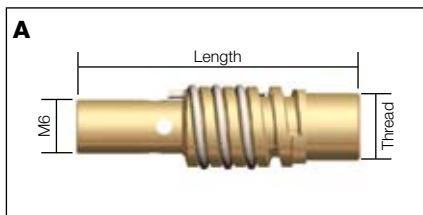
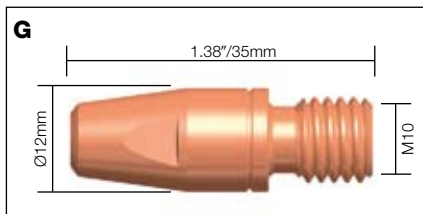
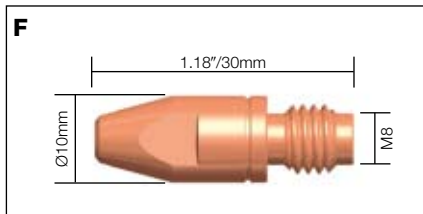
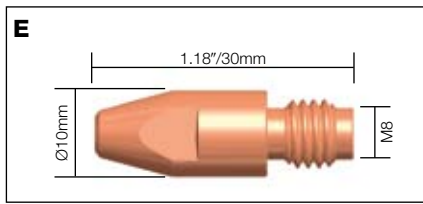

Tips					
Stock Code	Description	Wire Size	Wire Size	Material	Model
E B4014-08	Contact Tip	.030"	0.8mm	Ecu	SB360A-SB501W
B4014-09	Contact Tip	.035"	0.9mm	Ecu	SB360A-SB501W
B4014-10	Contact Tip	.040"	1.0mm	Ecu	SB360A-SB501W
ECO4014-10	Everyday Contact Tip	.040"	1.0mm	Ecu	SB360A-SB501W
B4014-12	Contact Tip	.045"	1.2mm	Ecu	SB360A-SB501W
ECO4014-12	Everyday Contact Tip	.045"	1.2mm	Ecu	SB360A-SB501W
B4014-14	Contact Tip	.055"	1.4mm	Ecu	SB360A-SB501W
B4014-16	Contact Tip	1/16"	1.6mm	Ecu	SB360A-SB501W
ECO4014-16	Everyday Contact Tip	1/16"	1.6mm	Ecu	SB360A-SB501W
B4014-20	Contact Tip	5/64"	2.0mm	Ecu	SB360A-SB501W
B4014-24	Contact Tip	3/32"	2.4mm	Ecu	SB360A-SB501W
B4014-10CR	Contact Tip, Cr Plated	.040"	1.0mm	Ecu	SB360A-SB501W
B4014-12CR	Contact Tip, Cr Plated	.045"	1.2mm	Ecu	SB360A-SB501W
B4014-10A	Contact Tip, Ali Wire	.040"	1.0mm	Ecu	SB360A-SB501W
B4014-12A	Contact Tip, Ali Wire	.045"	1.2mm	Ecu	SB360A-SB501W
B4014-16A	Contact Tip, Ali Wire	1/16"	1.6mm	Ecu	SB360A-SB501W

Stock Code	Description	Wire Size	Wire Size	Material	Model
F B4015-08	Contact Tip	.030"	0.8mm	CuCrZr	SB360A-SB501W
B4015-10	Contact Tip	.040"	1.0mm	CuCrZr	SB360A-SB501W
B4015-12	Contact Tip	.045"	1.2mm	CuCrZr	SB360A-SB501W
B4015-14	Contact Tip	.055"	1.4mm	CuCrZr	SB360A-SB501W
B4015-16	Contact Tip	1/16"	1.6mm	CuCrZr	SB360A-SB501W
B4015-24	Contact Tip	3/32"	2.4mm	CuCrZr	SB360A-SB501W

Stock Code	Description	Wire Size	Wire Size	Material	Model
G B6015-14	Contact Tip	.055"	1.4mm	CuCrZr	SB610A, SB610W
B6015-16	Contact Tip	1/16"	1.6mm	CuCrZr	SB610A, SB610W
B6015-20	Contact Tip	5/64"	2.0mm	CuCrZr	SB610A, SB610W
B6015-24	Contact Tip	3/32"	2.4mm	CuCrZr	SB610A, SB610W
B6015-28	Contact Tip	.110"	2.8mm	CuCrZr	SB610A, SB610W
B6015-32	Contact Tip	1/8"	3.2mm	CuCrZr	SB610A, SB610W

Tip Adaptors						
Stock Code	Description	Tip Thread	Neck Thread	Model	Length	Length
A B1507/LH	Tip Adaptor	M6	M8x1 L/H	SB150A	1.65"	42mm
B1507	Tip Adaptor	M6	M8x1	SB140A	1.34"	34mm

Stock Code	Description	Tip Thread	Neck Thread	Model
B B2412	Tip Adaptor	M6	M6	SB230A, SB240A/W

Stock Code	Description	Tip Thread	Neck Thread	Model
C B2506	Tip Adaptor	M6	M8	SB250A, SB350W
ECO2506	Everyday Tip Adaptor	M6	M8	SB250A, SB350W

# BZL Tip Adaptors

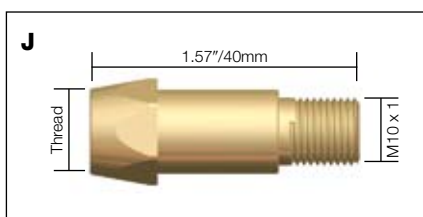
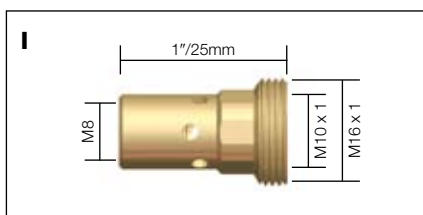
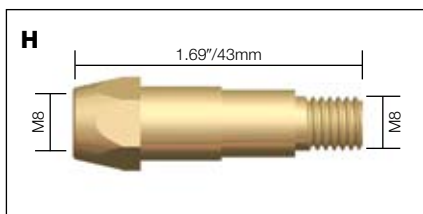
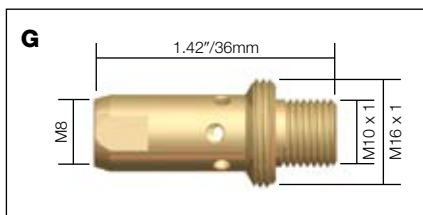
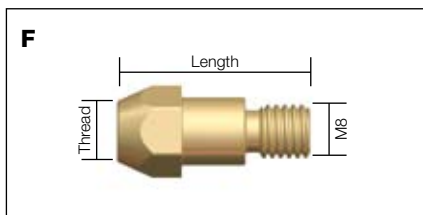
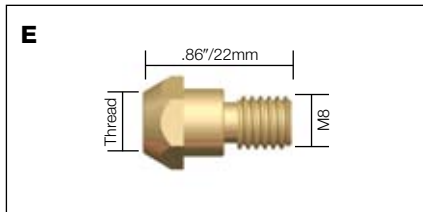
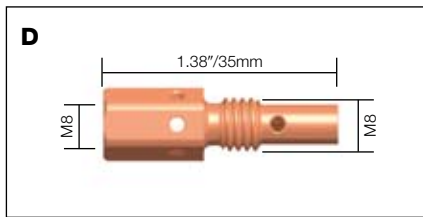

Tip Adaptors				
Stock Code	Description	Tip Thread	Neck Thread	Model
D B2536	Tip Adaptor	M8	M8	SB250A, SB350W

Stock Code	Description	Tip Thread	Neck Thread	Model
E B2612	Tip Adaptor	M6	M8	SB260A
B2612M8	Tip Adaptor	M8	M8	SB260A

Stock Code	Description	Tip Thread	Length	Length	Neck Thread	Model
F B3612	Tip Adaptor	M6	1.12"	28.5mm	M8	SB360A
ECO3612	Everyday Tip Adaptor	M6	1.12"	28.5mm	M8	SB360A
B3613	Tip Adaptor	M6	1.24"	31.5mm	M8	SB360A
B3614	Tip Adaptor	M8	1.12"	28.5mm	M8	SB360A
ECO3614	Everyday Tip Adaptor	M8	1.12"	28.5mm	M8	SB360A

Stock Code	Description	Tip Thread	Neck Thread	Model
G B3812	Tip Adaptor	M8	M10 x 1	SB380A

Stock Code	Description	Tip Thread	Neck Thread	Model
H B4005	Tip Adaptor	M8	M8	SB400A

Stock Code	Description	Tip Thread	Neck Thread	Model
I B5001	Tip Adaptor	M8	M10 x 1	SB401W, SB501W
ECO5001	Everyday Tip Adaptor	M8	M10 x 1	SB401W, SB501W

Stock Code	Description	Tip Thread	Neck Thread	Model
J B6003	Tip Adaptor	M8	M10 x 1	SB610A, SB610W
B6003M10	Tip Adaptor	M10	M10 x 1	SB610A, SB610W

# BZL Gas Diffusers

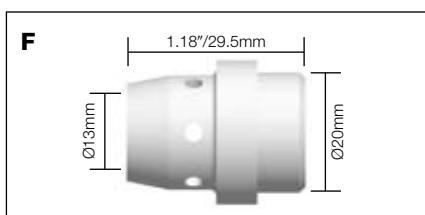
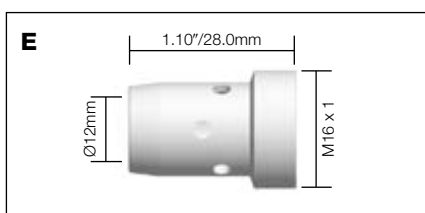
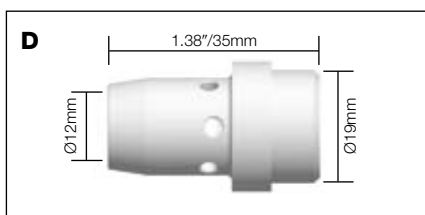
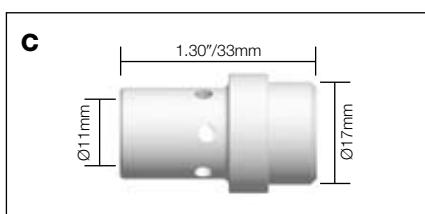
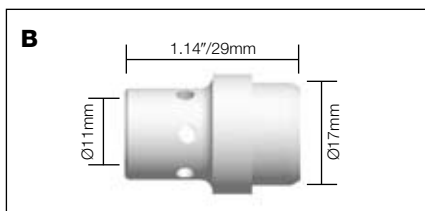
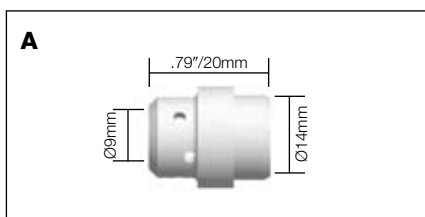

## Diffusers

Stock Code	Description	Colour	Model
<b>A</b> B2405B	Diffuser	Black	SB240A, SB240W
B2405C	Diffuser	Ceramic	SB240A, SB240W
B2405W	Diffuser	White	SB240A, SB240W

Stock Code	Description	Colour	Model
<b>B</b> B2605B	Diffuser	Black	SB260A
B2605C	Diffuser	Ceramic	SB260A
B2605W	Diffuser	White	SB260A

Stock Code	Description	Colour	Model
<b>C</b> B3605B	Diffuser	Black	SB360A
B3605C	Diffuser	Ceramic	SB360A
B3605W	Diffuser	White	SB360A

Stock Code	Description	Colour	Model
<b>D</b> B4003B	Diffuser	Black	SB400A
B4003C	Diffuser	Ceramic	SB400A

Stock Code	Description	Colour	Model
<b>E</b> B5005B	Diffuser	Black	SB380A, SB401W, SB501W
B5005C	Diffuser	Ceramic	SB380A, SB401W, SB501W
B5005W	Diffuser	White	SB380A, SB401W, SB501W

Stock Code	Description	Colour	Model
<b>F</b> B6002C	Diffuser	Ceramic	SB610A, SB610W

# BZL Robotic Consumables

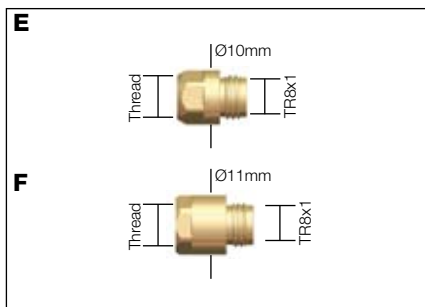
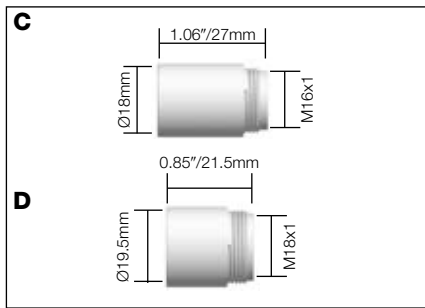

Nozzles				
Stock Code	Description	Bore	Bore	Model
<b>A</b> RB2408	Conical Nozzle	5/8"	15.5mm	ROBO 241
RB2409	Tapered Nozzle	1/2"	13mm	ROBO 241

Stock Code	Description	Bore	Bore	Model
<b>B</b> RB4508	Conical Nozzle	5/8"	15.5mm	ROBO 455
RB4509	Tapered Nozzle	1/2"	13mm	ROBO 455

Insulators			
Stock Code	Description	Thread Size	Model
<b>C</b> RB2405	Nozzle Insulator	M16x1	ROBO 241
<b>D</b> RB4505	Nozzle Insulator	M18x1	ROBO 455

Tip Adaptors			
Stock Code	Description	Thread Size	Model
<b>E</b> RB4512	Tip Adaptor	M6x1	ROBO 455
<b>F</b> RB4514	Tip Adaptor	M8x1.25	ROBO 455

Neck Liners				
Stock Code	Description	Wire Size	Wire Size	Model
<b>G</b> RB2498	Steel Neck Liner	.030"-.040"	0.8-1.0mm	ROBO 241, 455
RB2499	Steel Neck Liner	.040"-.045"	1.0-1.2mm	ROBO 241, 455

# BZL Liner Selector Chart

Liners Selector Chart					SB120A	SB140A	SB150A	SB230A	SB240A	SB250A	SB260A	SB360A	SB380A	SB400A	SB610A	SB240W	SB350W	SB401W	SB501W	SB610W
Stock Code	Description	Length	Wire Size	Model																
<b>A</b> B1435-30	Steel Liner	3mt	.023"-.030"/0.6mm-0.8mm		■	□	□	□	□	□	□	□	□	□		□	□	□	□	□
B1435-40	Steel Liner	4mt	.023"-.030"/0.6mm-0.8mm		■	□	□	□	□	□	□	□	□	□		□	□	□	□	□
B1435-20TEL	Steel Liner (Telwin)	2mt	.023"-.030"/0.6mm-0.8mm		■	□	□													
B1435-30TEL	Steel Liner (Telwin)	3mt	.023"-.030"/0.6mm-0.8mm		■	□	□													
B1436-30	Nylon Liner	3mt	.023"-.035"/0.6mm-0.9mm		■	□	□													
B1436-40	Nylon Liner	4mt	.023"-.035"/0.6mm-0.9mm		■	□	□													
<b>B</b> ECO / B1535-30	Steel Liner	3mt	.023"-.035"/0.6mm-0.9mm		■	■	■	■	■	■	■	■	□	□		□	□	□	□	□
ECO / B1535-40	Steel Liner	4mt	.023"-.035"/0.6mm-0.9mm		■	■	■	■	■	■	■	■	□	□		□	□	□	□	□
B1535-50	Steel Liner	5mt	.023"-.035"/0.6mm-0.9mm		■	■	■	■	■	■	■	■	□	□		□	□	□	□	□
B1535-20TEL	Steel Liner (Telwin)	2mt	.023"-.035"/0.6mm-0.9mm		■	■														
B1535-30TEL	Steel Liner (Telwin)	3mt	.023"-.035"/0.6mm-0.9mm		■	■														
<b>C</b> B1536-30++	Teflon Liner	3mt	.023"-.035"/0.6mm-0.9mm		■	■	■	■	■	■	■	■	□	□		■	■	□	□	□
B1536-40++	Teflon Liner	4mt	.023"-.035"/0.6mm-0.9mm		■	■	■	■	■	■	■	■	□	□		■	■	□	□	□
B1536-50++	Teflon Liner	5mt	.023"-.035"/0.6mm-0.9mm		■	■	■	■	■	■	■	■	□	□		■	■	□	□	□
<b>B</b> ECO / B2524-30	Steel Liner	3mt	.040"-.045"/1.0mm-1.2mm		□	□	■	■	■	■	■	■	■	■		□	□	□	□	□
ECO / B2524-40	Steel Liner	4mt	.040"-.045"/1.0mm-1.2mm		□	□	■	■	■	■	■	■	■	■		□	□	□	□	□
B2524-50	Steel Liner	5mt	.040"-.045"/1.0mm-1.2mm		□	□	■	■	■	■	■	■	■	■		□	□	□	□	□
<b>C</b> B2513-30++	Teflon Liner	3mt	.040"-.045"/1.0mm-1.2mm		□	□	■	■	■	■	■	■	■	■		□	□	■	■	■
B2513-40++	Teflon Liner	4mt	.040"-.045"/1.0mm-1.2mm		□	□	■	■	■	■	■	■	■	■		□	□	■	■	■
B2513-50++	Teflon Liner	5mt	.040"-.045"/1.0mm-1.2mm		□	□	■	■	■	■	■	■	■	■		□	□	■	■	■
<b>B</b> B3631-30	Steel Liner	3mt	1/16"/1.6mm		□	□	□	□	□	■	■	■	■		□	□	□	□	□	□
B3631-40	Steel Liner	4mt	1/16"/1.6mm		□	□	□	□	□	■	■	■	■		□	□	□	□	□	□
B3631-50	Steel Liner	5mt	1/16"/1.6mm		□	□	□	□	□	■	■	■	■		□	□	□	□	□	□
<b>C</b> B3626-30++	Teflon Liner	3mt	.045"-1/16"/1.2mm-1.6mm				□	□	□	■	■	■	■		□	□	■	■	□	□
B3626-40++	Teflon Liner	4mt	.045"-1/16"/1.2mm-1.6mm				□	□	□	■	■	■	■		□	□	■	■	□	□
B3626-50++	Teflon Liner	5mt	.045"-1/16"/1.2mm-1.6mm				□	□	□	■	■	■	■		□	□	■	■	□	□
<b>B</b> B4631-30	Steel Liner	3mt	5/64"-3/32"/2.0mm-2.4mm											■						
B4631-40	Steel Liner	4mt	5/64"-3/32"/2.0mm-2.4mm											■						
B4631-50	Steel Liner	5mt	5/64"-3/32"/2.0mm-2.4mm											■						
<b>D</b> B6033-30	Plain Liner (Rz-2)	3mt	1/16"-5/64"/1.6mm-2.0mm												■					■
B6033-40	Plain Liner (Rz-2)	4mt	1/16"-5/64"/1.6mm-2.0mm												■					■
B6033-50	Plain Liner (Rz-2)	5mt	1/16"-5/64"/1.6mm-2.0mm												■					■
<b>D</b> B6034-30	Plain Liner (Rz-2)	3mt	3/32"/2.4mm												■					■
B6034-40	Plain Liner (Rz-2)	4mt	3/32"/2.4mm												■					■
<b>D</b> B6035-30	Plain Liner (Rz-2)	3mt	.110"-1/8"/2.8mm-3.2mm												■					■
B6035-40	Plain Liner (Rz-2)	4mt	.110"-1/8"/2.8mm-3.2mm												■					■
<b>B</b> B5033-30	Plain Liner	3mt	.040"-.045"/1.0mm-1.2mm													■	■	■	■	■
B5033-40	Plain Liner	4mt	.040"-.045"/1.0mm-1.2mm													■	■	■	■	■
B5033-50	Plain Liner	5mt	.040"-.045"/1.0mm-1.2mm													■	■	■	■	■
<b>B</b> B5034-30	Plain Liner	3mt	.045"-1/16"/1.2mm-1.6mm													□	□	■	■	■
B5034-40	Plain Liner	4mt	.045"-1/16"/1.2mm-1.6mm													□	□	■	■	■
B5034-50	Plain Liner	5mt	.045"-1/16"/1.2mm-1.6mm													□	□	■	■	■
<b>A</b> B4033-30	Plain Liner	3mt	5/64"-3/32"/2.0mm-2.4mm													□	□	□	■	■
B4033-40	Plain Liner	4mt	5/64"-3/32"/2.0mm-2.4mm													□	□	□	■	■
B4033-50	Plain Liner	5mt	5/64"-3/32"/2.0mm-2.4mm													□	□	□	■	■
<b>C</b> B1564-30++	Polyamide Liner	3mt	.030"-.045"/0.8mm-1.2mm		■	■	■	■	■	■	■	■	■	■		■	■	□	□	□
B1564-40++	Polyamide Liner	4mt	.030"-.045"/0.8mm-1.2mm		■	■	■	■	■	■	■	■	■	■		■	■	□	□	□
B1564-50++	Polyamide Liner	5mt	.030"-.045"/0.8mm-1.2mm		■	■	■	■	■	■	■	■	■	■		■	■	□	□	□
<b>C</b> B2564-30++	Polyamide Liner	3mt	.045"-1/16"/1.2mm-1.6mm			□	□	■	■	■	■	■	■	■		□	■	■	■	■
B2564-40++	Polyamide Liner	4mt	.045"-1/16"/1.2mm-1.6mm			□	□	■	■	■	■	■	■	■		□	■	■	■	■
B2564-50++	Polyamide Liner	5mt	.045"-1/16"/1.2mm-1.6mm			□	□	■	■	■	■	■	■	■		□	■	■	■	■
<b>C</b> B3564-30++	Polyamide Liner	3mt	1/16"-5/64"/1.6mm-2.0mm			□	□	□	□	□	■	■	■	■		□	□	■	■	■
B3564-40++	Polyamide Liner	4mt	1/16"-5/64"/1.6mm-2.0mm			□	□	□	□	□	■	■	■	■		□	□	■	■	■
B3564-50++	Polyamide Liner	5mt	1/16"-5/64"/1.6mm-2.0mm			□	□	□	□	□	■	■	■	■		□	□	■	■	■
<b>C</b> B2554-30++	Carbon Teflon Liner	3mt	.040"-.045"/1.0mm-1.2mm		■	■	■	■	■	■	■	■	■	■		■	■	□	□	□
B2554-40++	Carbon Teflon Liner	4mt	.040"-.045"/1.0mm-1.2mm		■	■	■	■	■	■	■	■	■	■		■	■	□	□	□
B2554-50++	Carbon Teflon Liner	5mt	.040"-.045"/1.0mm-1.2mm		■	■	■	■	■	■	■	■	■	■		■	■	□	□	□
<b>C</b> B3554-30++	Carbon Teflon Liner	3mt	.045"-1/16"/1.2mm-1.6mm			□	□	■	■	■	■	■	■	■		□	■	■	■	■
B3554-40++	Carbon Teflon Liner	4mt	.045"-1/16"/1.2mm-1.6mm			□	□	■	■	■	■	■	■	■		□	■	■	■	■
B3554-50++	Carbon Teflon Liner	5mt	.045"-1/16"/1.2mm-1.6mm			□	□	■	■	■	■	■	■	■		□	■	■	■	■

■ Solid Box = Recommended Liner □ Clear Box = Compatible Liner ++ For optional Neck Liners please use the following codes.  
 B9000 for soft wires .030"-.045"/0.8mm-1.0mm, B9001 for .040"-1/16"/1.0mm-1.6mm

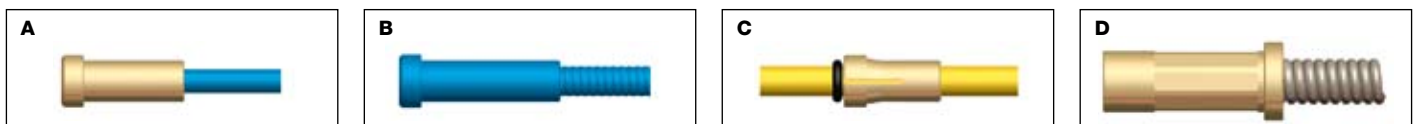

# Everyday 150A

## Air Cooled MIG Welding Torch

Rating: 180A CO2 150A mixed gas, @ 60% duty cycle. EN60974-7 .023"-.040"/0.6-1.0mm wires

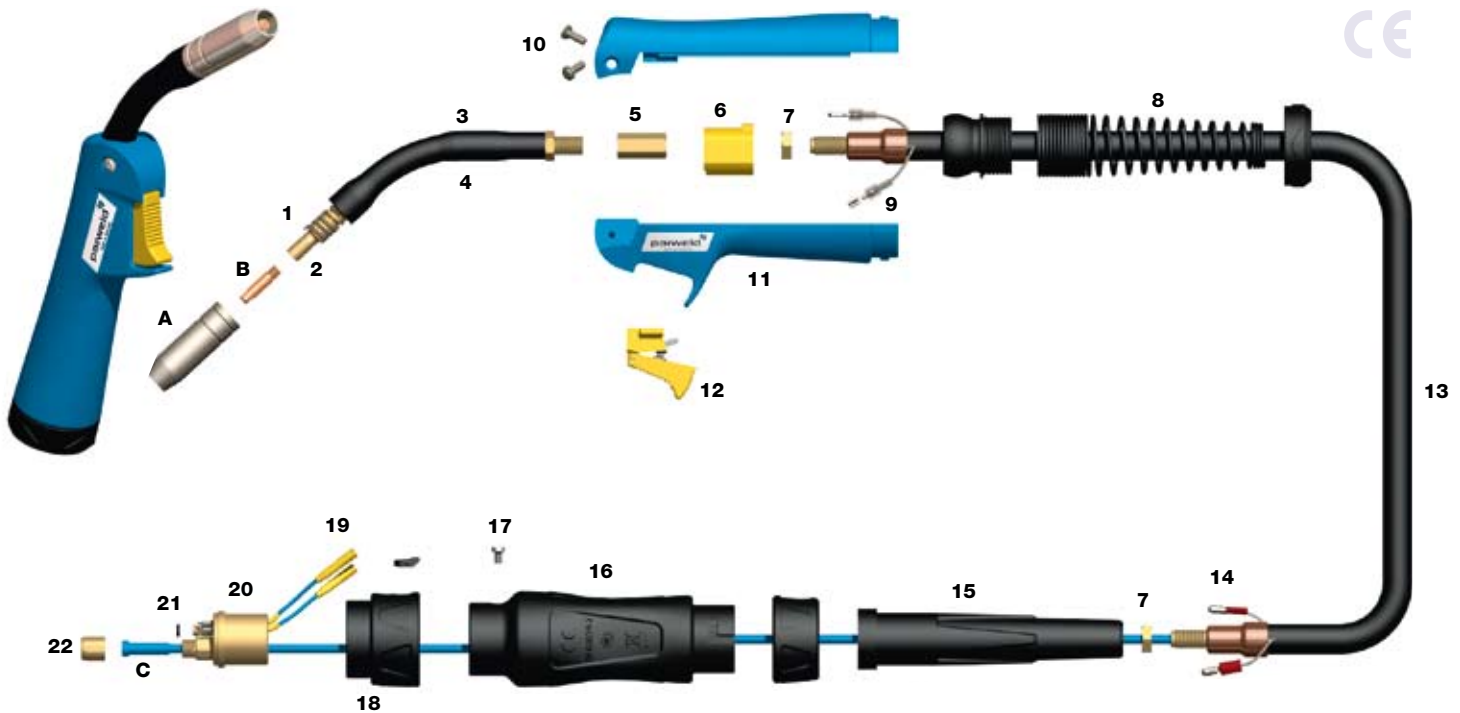

Model			
Stock Code	3M	4M	Model Description
ECR1500	-30ER	-40ER	Everyday Welding Torch c/w Euro Fitting

Nozzles	
Stock Code	Description
A	ECO1530* Everyday Conical Nozzle 15/32"/12mm Bore
	B1529 Everyday Cylindrical Nozzle 5/8"/16mm Bore
	B1531 Everyday Tapered Nozzle 7/16"/11mm Bore
	B1532 Everyday Bottle Nozzle 1/2"/13mm Bore
	B1533 Everyday Spot Welding Nozzle 5/8"/16mm Bore

Contact Tips	
Stock Code	Description
B	ECO1527-06 Everyday Contact Tip 0.023"/0.6mm M6 Eco
	ECO1527-08* Everyday Contact Tip 0.030"/0.8mm M6 Eco

Liners	
Stock Code	Description
C	ECO1535-30 Everyday Steel Liner .023"-.030"/0.6-0.9mm x 3m
	ECO1535-40 Everyday Steel Liner .023"-.030"/0.6-0.9mm x 4m

Components		
Stock Code	Description	* Denotes Standard Build
1	B1504 Shroud Spring	
2	B1507 L/H Tip Adaptor	
3	ECO1501 Swan Neck c/w Tip Adaptor & Insulation Sleeve	
4	ECO1502 One Piece Neck Insulation Sleeve	
5	B2519 Hexagonal Fitting	
6	B1515/ER Ergo Handle Location Body	
7	B1505 Lock Nut	
8	ECO8016 Spring Cable Support c/w Knuckle Joint	
9	B1521 Cable Terminal – Female	
10	B1541 Handle Screw	
11	ECO2514 Everyday Ergo Handle Kit	
12	ECO2516 Everyday Ergo Trigger	
13	B1517-30 Cable Assembly x 3.0m	
	B1517-40 Cable Assembly x 4.0m	
	B1517-50 Cable Assembly x 5.0m	
14	B1522 Cable Terminal – Male	
15	B1841 Cable Support	
16	B1518/BK Gun Plug Housing c/w Nut	
17	B1526 Gun Plug Screw	
18	B1519PL/BK Gun Plug Nut, Plastic c/w Insert	
19	Fixed Pin Fixed Pin Assembly	
20	ECB1528 Gun Plug Body c/w Fixed Pins	
21	B1524 Gun Plug 'O' Ring	
22	B1525 Liner Nut	

### Copyright

Parweld®. All rights reserved. No part of this publication may be reproduced, stored or transmitted by any means without prior permission of Parweld® the copyright holder.

# Everyday 250A

## Air Cooled MIG Welding Torch

Rating: 230A CO2 200A mixed gas, @ 60% duty cycle. EN60974-7. .030"- .045"/0.8-1.2mm wires

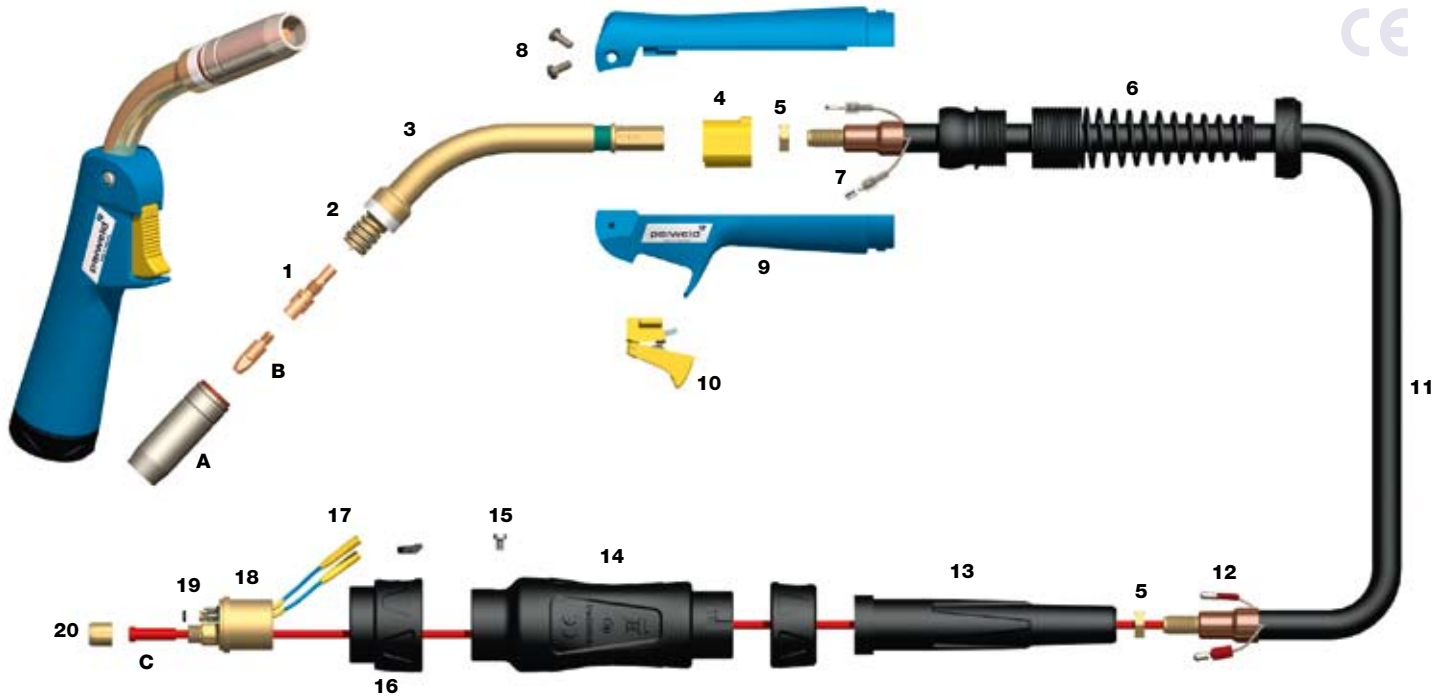

Model				
Stock Code	3M	4M	5M	Model Description
ECR2500	-30ER	-40ER	-50ER	Everyday Welding Torch c/w Euro Fitting

Nozzles	
Stock Code	Description
A ECO2507	Everyday Cylindrical Nozzle 1/16"/18mm Bore
ECO2508*	Everyday Conical Nozzle 9/32"/15mm Bore
ECO2509	Everyday Tapered Nozzle 15/32"/12mm Bore

Contact Tips	
Stock Code	Description
B ECO2504-08*	Everyday Contact Tip .030"/0.8mm M6 Ecu
ECO2504-10	Everyday Contact Tip .040"/1.0mm M6 Ecu
ECO2504-12	Everyday Contact Tip .045"/1.2mm M6 Ecu
ECO2505-08	Everyday Contact Tip .030"/0.8mm M6 CuCrZr
ECO2505-10	Everyday Contact Tip .040"/1.0mm M6 CuCrZr
ECO2504-12	Everyday Contact Tip .045"/1.2mm M6 CuCrZr

Liners	
Stock Code	Description
C ECO1535-30	Everyday Steel Liner .023"- .035"/0.6-0.9mm x 3mt
ECO1535-40	Everyday Steel Liner .023"- .035"/0.6-0.9mm x 4mt
ECO1535-50	Everyday Steel Liner .023"- .035"/0.6-0.9mm x 5mt
ECO2524-30*	Everyday Steel Liner .040"- .045"/1.0-1.2mm x 3mt
ECO2524-40*	Everyday Steel Liner .040"- .045"/1.0-1.2mm x 4mt
ECO2524-50*	Everyday Steel Liner .050"- .045"/1.0-1.2mm x 5mt

Components			
Stock Code	Description		* Denotes Standard Build
1	ECO2506	Tip Adaptor	
2	B2502	Shroud Spring	
3	ECO2501	Swan Neck	
4	B1515/ER	Ergo Handle Location Body	
5	B1505	Lock Nut, M10	
6	ECO8016	Cable Spring Support c/w Knuckle Joint	
7	B1521	Cable Terminal – Female	
8	B1541	Handle Screw	
9	ECO2514	Everyday Ergo Handle Kit	
10	ECO2516	Everyday Ergo Trigger	
11	B2503-30	Cable Assembly x 3.0m	
	B2503-40	Cable Assembly x 4.0m	
	B2503-50	Cable Assembly x 5.0m	
12	B1522	Cable Terminal – Male	
13	B1841	Cable Support	
14	B1518/BK	A/C Gun Plug Housing c/w Nut	
15	B1526	Gun Plug Screw	
16	B1519/BK	Gun Plug Nut c/w Insert	
17	Fixed Pin	Fixed Pin Assembly	
18	ECB1528	Gun Plug Body c/w Fixed Pins	
19	B1524	Gun Plug 'O' Ring	
20	B1525	Liner Nut	

# Everyday 360A

## Air Cooled MIG Welding Torch

Rating: 260A CO<sub>2</sub> 230A mixed gas, @ 60% duty cycle. EN60974-7.030"-.045"/0.8-1.2mm wires

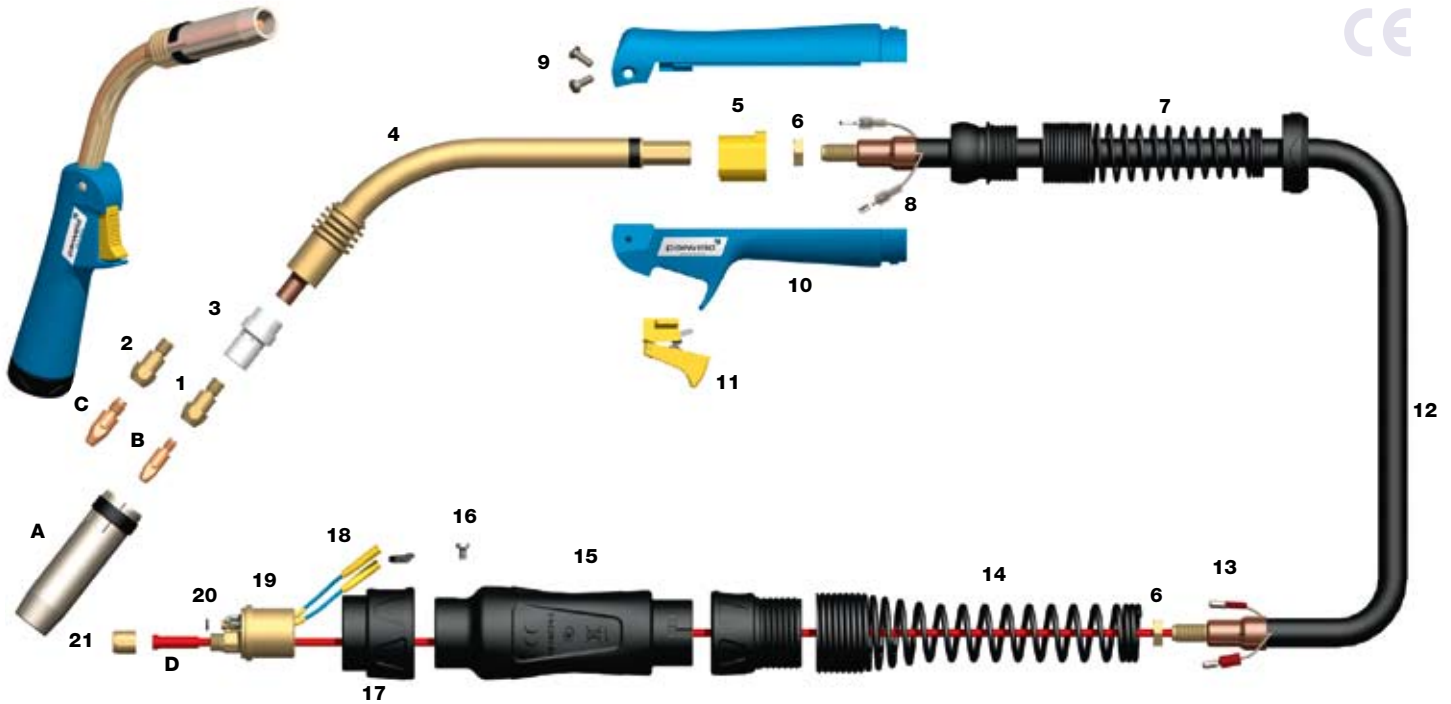

Model	3M	4M	5M	Model Description
ECR3600	-30ER	40ER	-50ER	Everyday Welding Torch c/w Euro Fitting

Nozzles	
Stock Code	Description
A ECO3615	Everyday Cylindrical Nozzle, 3/4"/19mm Bore
ECO3616*	Everyday Conical Nozzle, 5/8"/16mm Bore
ECO3617	Everyday Tapered Nozzle, 15/32"/12mm Bore

Contact Tips	
Stock Code	Description
B ECO2504-08	Everyday Contact Tip .030"/0.8mm M6 Ecu
ECO2504-10	Everyday Contact Tip .040"/1.0mm M6 Ecu
ECO2504-12*	Everyday Contact Tip .045"/1.2mm M6 Ecu
ECO2505-08	Everyday Contact Tip .030"/0.8mm M6 CuCrZr
ECO2505-10	Everyday Contact Tip .040"/1.0mm M6 CuCrZr
ECO2505-12	Everyday Contact Tip .045"/1.2mm M6 CuCrZr
C ECO4014-10	Everyday Contact Tip .040"/1.0mm M8 Ecu
ECO4014-12	Everyday Contact Tip .045"/1.2mm M8 Ecu

Liners	
Stock Code	Description
D ECO1535-30	Everyday Steel Liner .023"-.035"/0.6-0.9mm x 3mt
ECO1535-40	Everyday Steel Liner .023"-.035"/0.6-0.9mm x 4mt
ECO1535-50	Everyday Steel Liner .023"-.035"/0.6-0.9mm x 5mt
ECO2524-30*	Everyday Steel Liner .040"-.045"/1.0-1.2mm x 3mt
ECO2524-40*	Everyday Steel Liner .040"-.045"/1.0-1.2mm x 4mt
ECO2524-50	Everyday Steel Liner .040"-.045"/1.0-1.2mm x 5mt

Components		
Stock Code	Description	* Denotes Standard Build
1	ECO3612*	Tip Adaptor, 28.5mm, M6
2	ECO3614	Tip Adaptor, 28.5mm, M8
3	B3605B	Diffuser Black
	B3605C	Diffuser Ceramic
	B3605W*	Diffuser White
4	ECO3603	Swan Neck
5	B1515/ER	Ergo Handle Location Body
6	B1505	Lock Nut
7	ECO8018	Cable Spring Support
8	B1521	Cable Terminal – Female
9	B1541	Handle Screw
10	ECO2514	Everyday Ergo Handle Kit
11	ECO2516	Everyday Ergo Trigger
12	B3609-30	Cable Assembly x 3.0m
	B3609-40	Cable Assembly x 4.0m
	B3609-50	Cable Assembly x 5.0m
13	B1522	Cable Terminal – Male
14	B8026	Cable Support
15	B1518/BK	Gun Plug Housing c/w Nut
16	B1526	Gun Plug Screw
17	B1519/BK	Gun Plug Nut c/w Insert
18	Fixed Pin	Fixed Pin Assembly
19	ECB1528	Gun Plug Body c/w Fixed Pins
20	B1524	Gun Plug 'O' Ring
21	B1525	Liner Nut

# Everyday 501W

## Water Cooled MIG Welding Torch

Rating: 400A CO<sub>2</sub> 360A mixed gas, @100% duty cycle. EN60974-7 .040"-1/16"/1.0-1.6mm wires

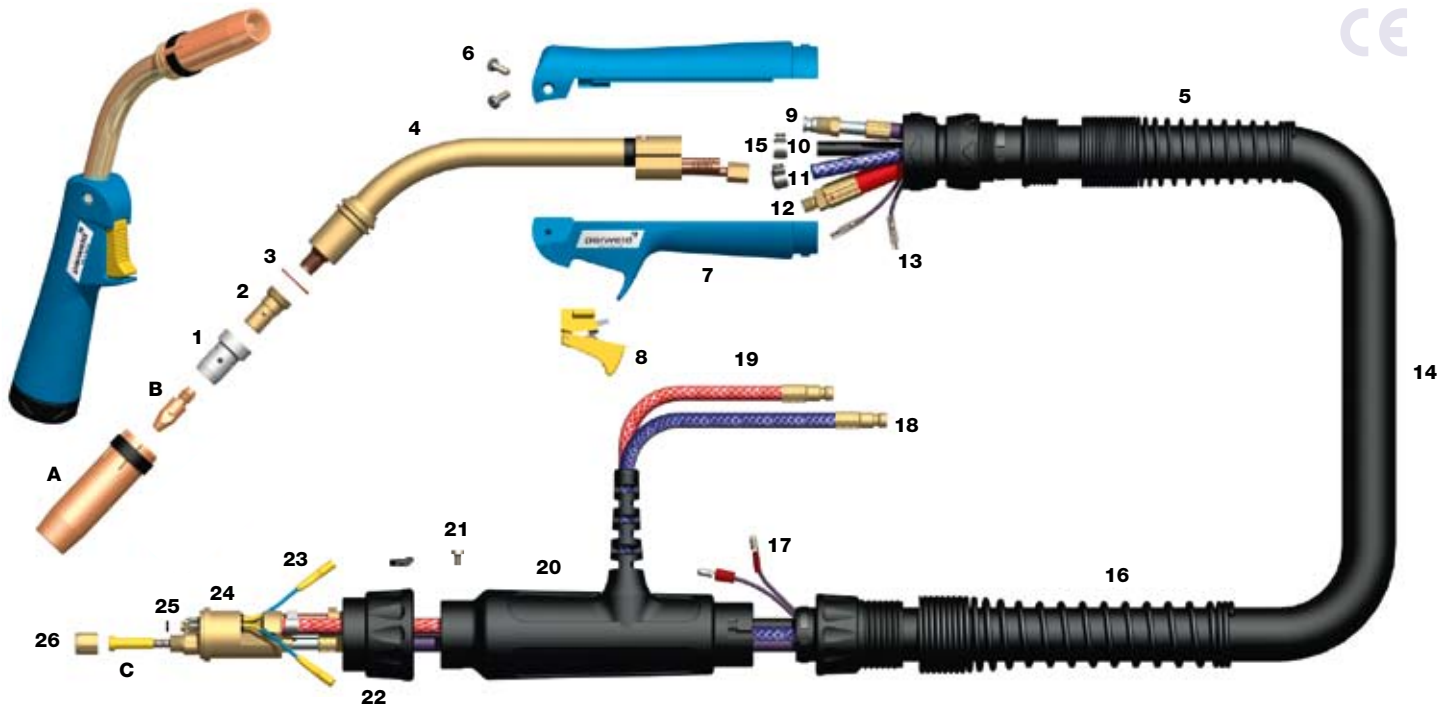

Model	3M	4M	Model Description
Stock Code	3M	4M	Model Description
ECR5000	-30ER	-40ER	Everyday Welding Torch c/w Euro Fitting

Nozzles	
Stock Code	Description
<b>A</b> ECO5027	Everyday Cylindrical Nozzle 3/4"/19mm Bore
ECO5028*	Everyday Conical Nozzle 5/8"/16mm Bore
ECO5029	Everyday Tapered Nozzle 15/32"/12mm Bore

Contact Tips	
Stock Code	Description
<b>B</b> ECO4014-10	Everyday Contact Tip .040"/1.0mm M8 Ecu
ECO4014-12	Everyday Contact Tip .045"/1.2mm M8 Ecu
ECO4014-16	Everyday Contact Tip 1/16"/1.6mm M8 Ecu
B4015-10	Contact Tip .040"/1.0mm M8 CuCrZr
B4015-12*	Contact Tip .045"/1.2mm M8 CuCrZr
B4015-16	Contact Tip 1/16"/1.6mm M8 CuCrZr

Liners	
Stock Code	Description
<b>C</b> B5033-30	Plain Liner .040-.045"/1.0-1.2mm x 3mt
B5033-40	Plain Liner .040-.045"/1.0-1.2mm x 4mt
B5034-30*	Plain Liner .045"-1/16"/1.2-1.6mm x 3mt
B5034-40*	Plain Liner .045-1/16"/1.2-1.6mm x 4mt
B4033-30	Plain Liner .080-.090"/2.0-2.4mm x 3mt
B4033-40	Plain Liner .080-.090"/2.0-2.4mm x 4mt
B2513-30	Teflon Liner .040-.045"/1.0-1.2mm x 3mt
B2513-40	Teflon Liner .040-.045"/1.0-1.2mm x 4mt
B3626-30	Teflon Liner .045"-1/16"/1.2mm-1.6mm x 3mt
B3626-40	Teflon Liner .045"-1/16"/1.2mm-1.6mm x 4mt

Components		
Stock Code	Description	* Denotes Standard Build
<b>1</b> B5005B	Diffuser Black	
B5005C	Diffuser Ceramic	
B5005W*	Diffuser White	
<b>2</b> ECO5001	Tip Adaptor, 25.0mm, M8	
<b>3</b> B5003	Insulating Washer	
<b>4</b> ECO5002	Everyday Swan Neck	
<b>5</b> ECO8032	Cable Spring Support c/w Adaptor	
<b>6</b> B1541	Handle Screw	
<b>7</b> ECO2594	Everyday Ergo Handle Kit	
ECO8032	Adaptor	
<b>8</b> ECO2516	Everyday Ergo Trigger	
<b>15</b> B5024	Water Hose Clamp, 9.5mm	
<b>16</b> B8027	Spring Cable Support	
<b>17</b> B1522	Cable Terminal – Male	
<b>18</b> B5023	Water Hose Nipple	
<b>19</b> B5017 PVC	Water Outlet Hose	
<b>20</b> B5022/BK	Water Cooled Gun Plug Housing	
<b>21</b> B1526	Gun Plug Screw	
<b>22</b> B1519	Gun Plug Nut	
<b>23</b> B1523	Gun Plug Terminal	
<b>24</b> ECB5098	Gun Plug Body c/w Fixed Pins	
<b>25</b> B1524	Gun Plug 'O' Ring	
<b>26</b> B1525	Liner Nut	

Components				
Stock Code	3M	4M	Model Description	
<b>9</b> B5008	-30	-40	Outer Liner Assembly	
<b>10</b> B5013	-30	-40	Gas Hose Assembly, PVC	
<b>11</b> B5012	-30	-40	Water Inlet Hose Assembly, PVC	
<b>12</b> B5015	-30	-40	Power Cable Assembly, PVC	
<b>13</b> B5010	-30	-40	Switch Lead Assembly	
<b>14</b> B5019	-30	-40	Canvas Cover Assembly	

# SB 120A

## Air Cooled MIG Welding Torch

Rating: 140A CO<sub>2</sub> 120A mixed gas, @ 60% duty cycle. EN60974-7 .023"-.030"/0.6mm-0.8mm wires

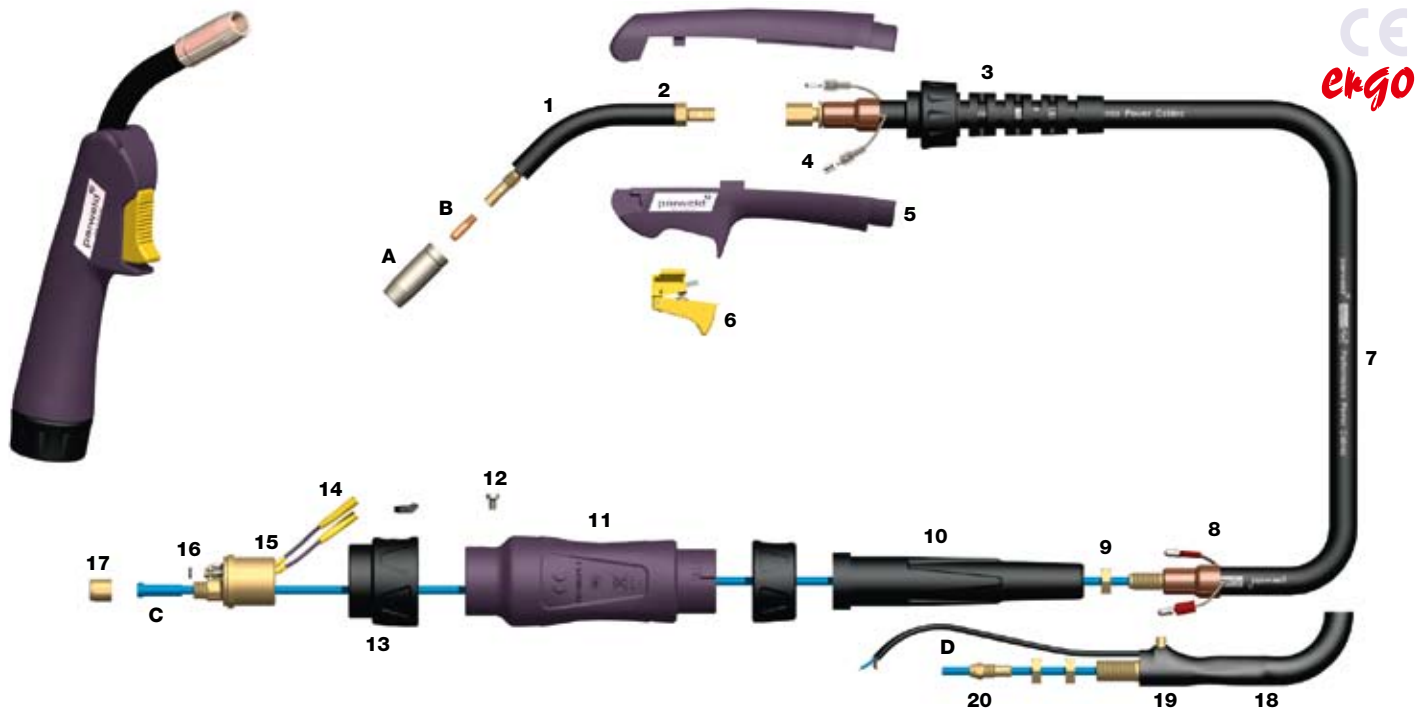

Model			
Stock Code	3M	4M	Model Description
B1200	-30ER	-40ER	Welding Torch c/w Euro Fitting
B1200	-30TEL	N/A	Welding Torch c/w Telwin Termination

Nozzles	
Stock Code	Description
A B1430*	Conical Nozzle Screw On 7/16"/11mm Bore
B1431	Spot Welding Nozzle Screw On 1/2"/13mm Bore

Contact Tips	
Stock Code	Description
B B1427-06*	Contact Tip .023"/0.6mm M5 Ecu
B1427-08	Contact Tip .030"/0.8mm M5 Ecu

Liners	
Stock Code	Description
C B1435-30*	Steel Liner .023"-.030"/0.6-0.8mm x 3mt
B1435-40*	Steel Liner .023"-.035"/0.6-0.8mm x 4mt
B1436-30	Nylon Liner .023"-.035"/0.6-0.8mm x 3mt
B1436-40	Nylon Liner .023"-.035"/0.6-0.8mm x 4mt
D B1535-30TEL	Steel Liner .023"-.035"/0.6-0.8mm x 3mt
B1535-40TEL	Steel Liner .023"-.035"/0.6-0.8mm x 4mt

Components		
Stock Code	Description	* Denotes Standard Build
1	B1401	Swan Neck
NI	B1401-P	Swan Neck – Push On Nozzle
2	B1402	Swan Neck
3	B8011	Cable Support
4	B1521	Cable Terminal
5	B1414	Ergo Handle Kit c/w Lock Nut and Trigger
6	B1416	Ergo Trigger
7	B1317-30	Hyperflex Cable Assembly x 3mt
	B1317-40	Hyperflex Cable Assembly x 4mt
8	B1522	Cable Terminal Male
9	B1505	Lock Nut
10	B1841	Cable Support
11	B1518	Gun Plug Housing c/w Nut
12	B1526	Gun Plug Screw
13	B1519PL	Gun Plug Nut-c/w Insert
14	Spring Pin 2	Spring Pin Assembly
15	B1528	Gun Plug Body c/w Spring Pins
16	B1524	Gun Plug 'O' Ring
17	B1525	Liner Nut
18	B1251	Strain Relief
19	B1217-30TEL	Hyperflex Cable Assy x 3mt Telwin
20	B1552	Liner Collet

# SB 140A

## Air Cooled MIG Welding Torch

Rating: 160A CO2 140A mixed gas @ 60% duty cycle EN60974-7, .023"-.035"/0.6mm-0.9mm wires

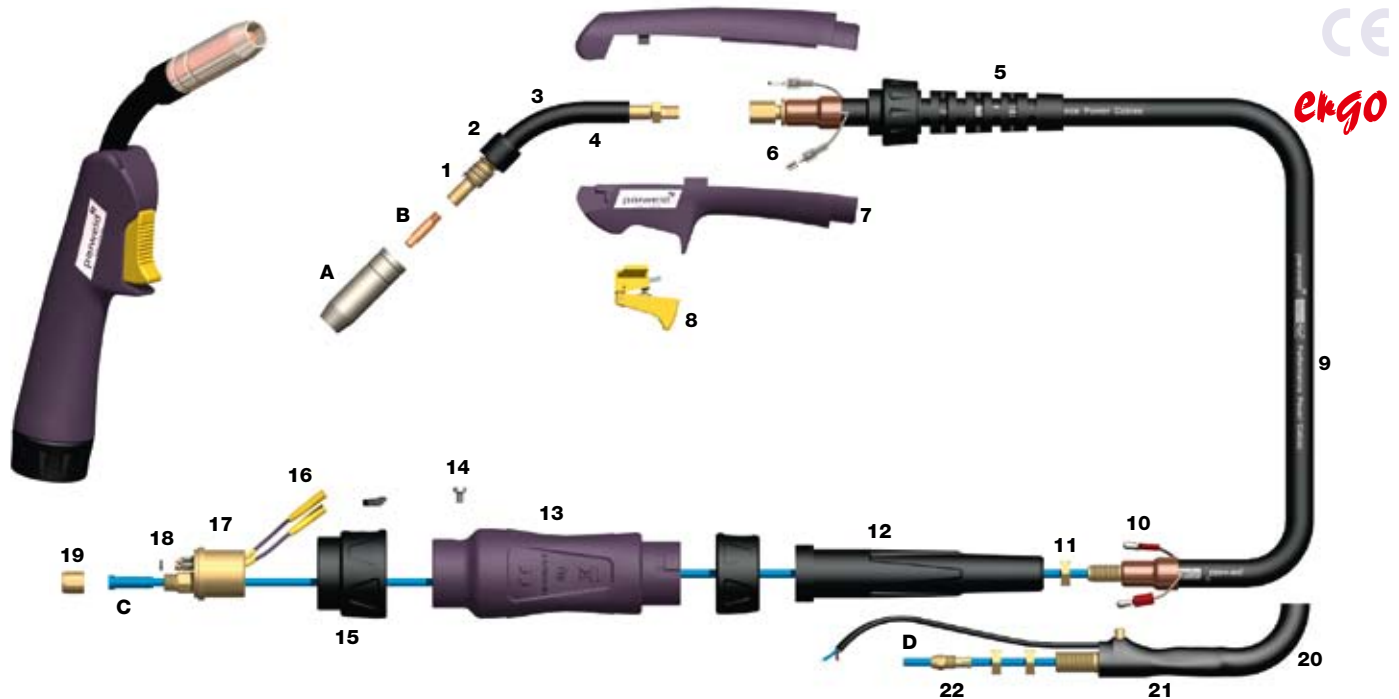

Model			
Stock Code	3M	4M	Model Description
B1400	-30ER	40ER	Welding Torch c/w Euro Fitting
B1400	-30TEL	N/A	Welding Torch c/w Telwin Termination

Nozzles	
Stock Code	Description
<b>A</b> B1529	Cylindrical Nozzle 5/8"/16mm Bore
B1530*	Conical Nozzle 15/32"/12mm Bore
B1531	Tapered Nozzle 7/16"/11mm Bore
B1532	Bottle Nozzle 1/2"/13mm Bore
B1533	Spot Welding Nozzle 5/8"/16mm Bore

Contact Tips	
Stock Code	Description
<b>B</b> B1527-06	Contact Tip .023"/0.6mm M6 Ecu
B1527-08*	Contact Tip .030"/0.8mm M6 Ecu
B1527-09	Contact Tip .035"/0.9mm M6 Ecu

Liners	
Stock Code	Description
<b>C</b> B1535-30*	Steel Liner .023"-.035"/0.6-0.9mm x 3mt
B1535-40*	Steel Liner .023"-.035"/0.6-0.9mm x 4mt
B1536-30	Teflon Liner .023"-.035"/0.6-0.9mm x 3mt
B1536-40	Teflon Liner .023"-.035"/0.6-0.9mm x 4mt
<b>D</b> B1535-30TEL	Steel Liner .023"-.035"/0.6-0.9mm x 3mt
B1535-40TEL	Steel Liner .023"-.035"/0.6-0.9mm x 4mt

Components		
Stock Code	Description	* Denotes Standard Build
<b>1</b> B1504	Shroud Spring	
<b>2</b> B1503	Insulator	
<b>3</b> B1502	Insulation Sleeve	
<b>4</b> B1415	Swan Neck	
<b>5</b> B8011	Cable Support	
<b>6</b> B1521	Cable Terminal	
<b>7</b> B1414	Ergo Handle Kit c/w Lock Nut and Trigger	
<b>8</b> B1416	Ergo Trigger	
<b>9</b> B1417-30	Hyperflex Cable Assembly x 3mt	
B1417-40	Hyperflex Cable Assembly x 4mt	
<b>10</b> B1522	Cable Terminal Male	
<b>11</b> B1505	Lock Nut	
<b>12</b> B1841	Cable Support	
<b>13</b> B1518	Gun Plug Housing c/w Nut	
<b>14</b> B1526	Gun Plug Screw	
<b>15</b> B1519PL	Gun Plug Nut c/w Insert	
<b>16</b> Spring Pin 2	Spring Pin Assembly	
<b>17</b> B1528	Gun Plug Body c/w Spring Pins	
<b>18</b> B1524	Gun Plug 'O' Ring	
<b>19</b> B1525	Liner Nut	
<b>20</b> B1251	Strain Relief	
<b>21</b> B1217-30TEL	Hyperflex Cable Assy x 3mt Telwin	
<b>22</b> B1552	Liner Collet	

# SB 150A

## Air Cooled MIG Welding Torch

Rating: 180A CO2 150A mixed gas @ 60% duty cycle, EN60974-7. .023"-.040"/0.6mm-1.0mm wire

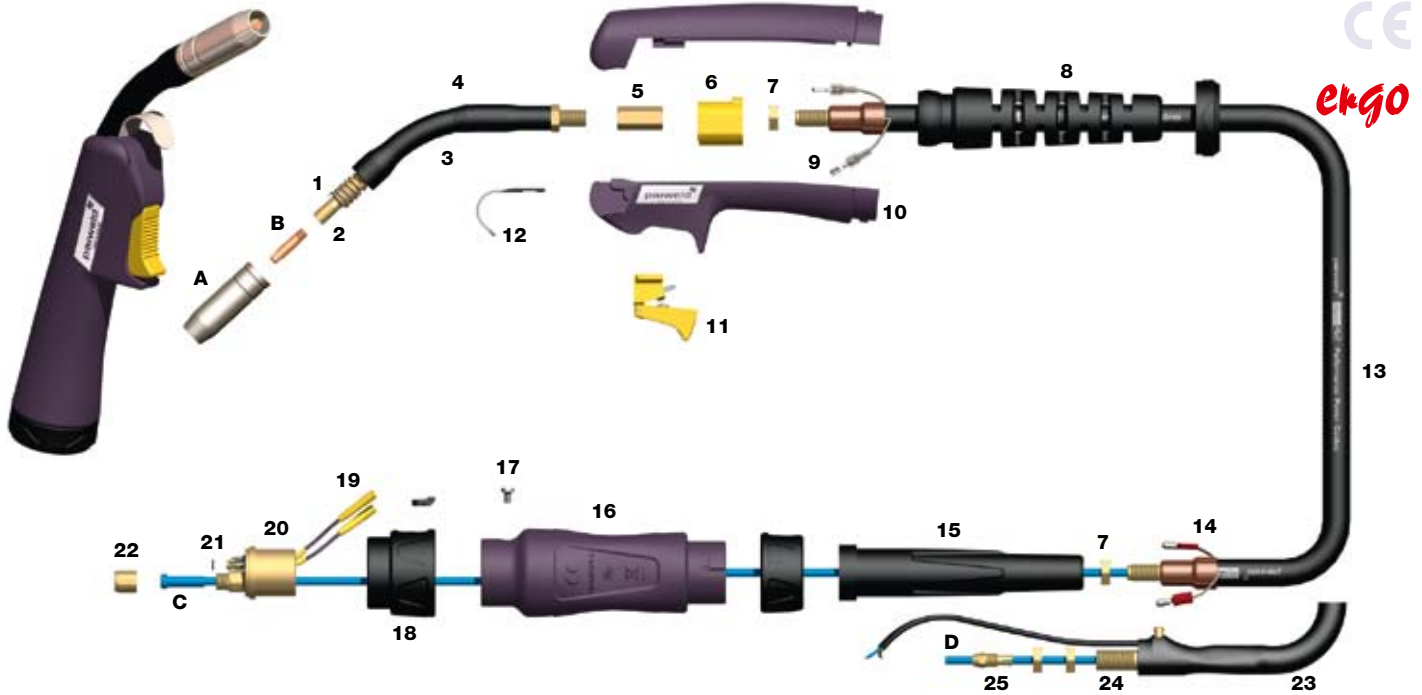

Model	Stock Code 3M	4M	5M	Model Description
B1500	-30ER	-40ER	-50ER	Welding Torch c/w Ergo Handle
B1500	-30EB	-40EB	-50EB	Welding Torch c/w Bladeswitch Handle
B1500	-30EM	-40EM	-50EM	Welding Torch c/w Microswitch Handle
B1500	-30TEL	-40TEL	-50TEL	Welding Torch c/w Telwin Fitting

Nozzles	
Stock Code	Description
A B1529	Cylindrical Nozzle 5/8"/16mm Bore
B1530*	Conical Nozzle 15/32"/12mm Bore
B1531	Tapered Nozzle 7/16"/11mm Bore
B1532	Bottle Nozzle 1/2"/13mm Bore
B1533	Spot Welding Nozzle 5/8"/16mm Bore

Contact Tips	
Stock Code	Description
B B1527-06	Contact Tip .023"/0.6mm M6 Ecu
B1527-08*	Contact Tip .030"/0.8mm M6 Ecu
B1527-09	Contact Tip .035"/0.9mm M6 Ecu
B1527-10	Contact Tip .040"/1.0mm M6 Ecu

Liners	
Stock Code	Description
C B1535-30*	Steel Liner .023"-.035"/0.6-0.9mm x 3mt
B1535-40*	Steel Liner .023"-.035"/0.6-0.9mm x 4mt
B1535-50*	Steel Liner .023"-.035"/0.6-0.9mm x 5mt
B1536-30	Teflon Liner .023"-.035"/0.6-0.9mm x 3mt
B1536-40	Teflon Liner .023"-.035"/0.6-0.9mm x 4mt
B1536-50	Teflon Liner .023"-.035"/0.6-0.9mm x 5mt
D B1535-40TEL	Steel Liner .023"-.035"/0.6-0.9mm x 4mt
B1535-50TEL	Steel Liner .023"-.035"/0.6-0.9mm x 5mt

Components		
Stock Code	Description	* Denotes Standard Build
1	B1504	Shroud Spring
2	B1507 L/H	Tip Adaptor
3	B1501	Swan Neck c/w Tip Adaptor, Spring and Sleeve
4	B1502	Insulation Sleeve
5	B2519	Hexagonal Fitting
6	B1515/ER	Ergo Handle Location Body
7	B1505	Lock Nut
8	B8015	Cable Support c/w Knuckle Joint
9	B1521	Cable Terminal
10	B2514	Ergo Handle Kit c/w Lock Nut
11	B2516	Ergo Trigger
12	B2517	Hanger Hook
13	B1517-30	Hyperflex Cable Assembly x 3mt
	B1517-40	Hyperflex Cable Assembly x 4mt
	B1517-50	Hyperflex Cable Assembly x 5mt
14	B1522	Cable Terminal Male
15	B1841	Cable Support
16	B1518	Gun Plug Housing c/w Nut
17	B1526	Gun Plug Screw
18	B1519PL	Gun Plug Nut c/w Insert
19	Spring Pin 2	Spring Pin Assembly
20	B1528	Gun Plug Body c/w Spring Pins
21	B1524	Gun Plug 'O' Ring
22	B1525	Liner Nut
23	B1251	Strain Relief
24	B1217-30TEL	Hyperflex Cable Assembly x 3mt Telwin
	B1217-40TEL	Hyperflex Cable Assembly x 4mt Telwin
25	B1552	Liner Collet

# SB 150A FLEX

## Air Cooled MIG Welding Torch

Rating: 180A CO<sub>2</sub> 150A mixed gas @ 60% duty cycle, EN60974-7. .023"-.040"/0.6mm-1.0mm wires

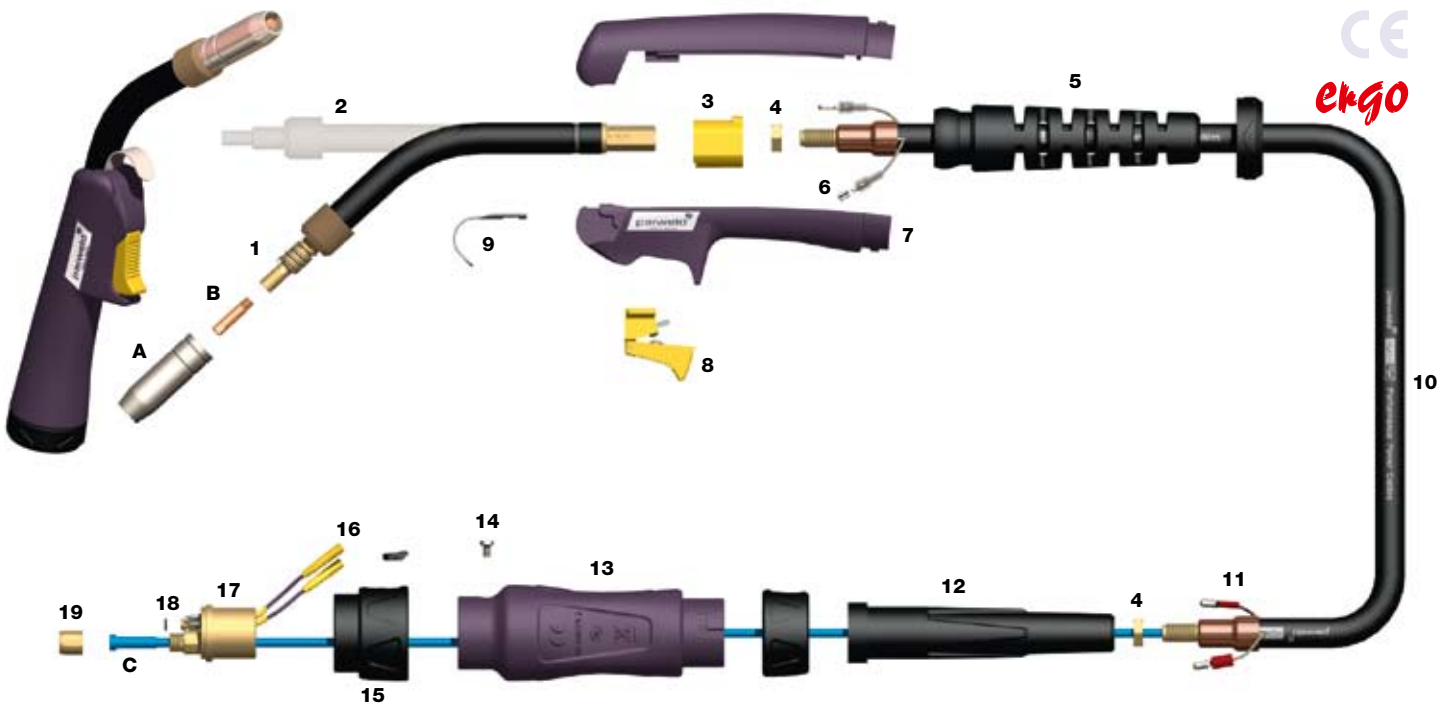

Model	3M	4M	Model Description
Stock Code	3M	4M	Model Description
B1500FX	-30ER	-40ER	Welding Torch c/w Euro Fitting

Nozzles	
Stock Code	Description
<b>A</b> B1529	Cylindrical Nozzle 5/8"/16mm Bore
B1530*	Conical Nozzle 15/32"/12mm Bore
B1531	Tapered Nozzle 7/16"/11mm Bore
B1532	Bottle Nozzle 1/2"/13mm Bore
B1533	Spot Welding Nozzle 5/8"/16mm Bore

Contact Tips	
Stock Code	Description
<b>B</b> B1527-06	Contact Tip .023"/0.6mm M6 Ecu
B1527-08*	Contact Tip .030"/0.8mm M6 Ecu
B1527-09	Contact Tip .035"/0.9mm M6 Ecu
B1527-10	Contact Tip .040"/1.0mm M6 Ecu

Liners	
Stock Code	Description
<b>C</b> B1535-30*	Steel Liner .023"-.035"/0.6-0.9mm x 3mt
B1535-40*	Steel Liner .023"-.035"/0.6-0.9mm x 4mt
B1536-30	Teflon Liner .023"-.035"/0.6-0.9mm x 3mt
B1536-40	Teflon Liner .023"-.035"/0.6-0.9mm x 4mt

Components		
Stock Code	Description	* Denotes Standard Build
<b>1</b> B1504	Shroud Spring	
<b>2</b> B1501FX	Swan Neck	
<b>3</b> B1515/ER	Ergo Handle Location Body	
<b>4</b> B1505	Lock Nut	
<b>5</b> B8015	Cable Support c/w Knuckle Joint	
<b>6</b> B1521	Cable Terminal	
<b>7</b> B2514	Ergo Handle Kit c/w Lock Nut	
<b>8</b> B2516	Ergo Trigger	
<b>9</b> B2517	Hanger Hook	
<b>10</b> B1517-30	Hyperflex Cable Assembly x 3mt	
B1517-40	Hyperflex Cable Assembly x 4mt	
<b>11</b> B1522	Cable Terminal Male	
<b>12</b> B1841	Cable Support	
<b>13</b> B1518	Gun Plug Housing c/w Nut	
<b>14</b> B1526	Gun Plug Screw	
<b>15</b> B1519PL	Gun Plug Nut c/w Insert	
<b>16</b> Spring Pin 2	Spring Pin Assembly	
<b>17</b> B1528	Gun Plug Body c/w Spring Pins	
<b>18</b> B1524	Gun Plug 'O' Ring	
<b>19</b> B1525	Liner Nut	

# SB 240A

## Air Cooled MIG Welding Torch

Rating: 250A CO2 220A mixed gas @ 60% duty cycle, EN60974-7. .030"-.045"/0.8mm-1.2mm wires

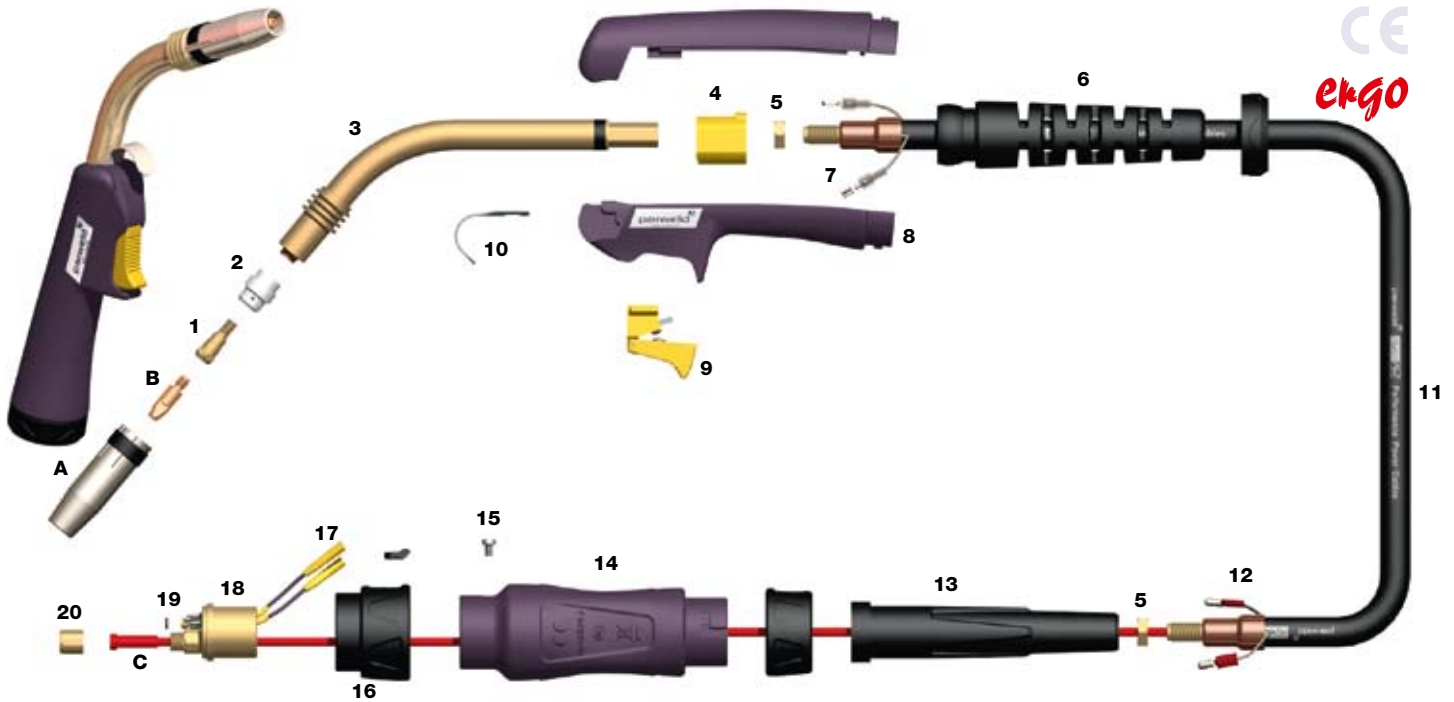

Model				
Stock Code	3M	4M	5M	Model Description
B2400	-30ER	-40ER	-50ER	Welding Torch c/w Ergo Handle
B2400	-30EB	-40EB	-50EB	Welding Torch c/w Bladeswitch Handle
B2400	-30EM	-40EM	-50EM	Welding Torch c/w Microswitch Handle

Nozzles	
Stock Code	Description
A B2415	Cylindrical Nozzle 43/64"/17mm Bore
B2416*	Conical Nozzle 1/2"/13mm Bore
B2417	Tapered Nozzle 3/8"/10mm Bore

Contact Tips	
Stock Code	Description
B B2504-08	Contact Tip .030"/0.8mm M6 Ecu
B2504-09	Contact Tip .035"/0.9mm M6 Ecu
B2504-10*	Contact Tip .040"/1.0mm M6 Ecu
B2504-12	Contact Tip .045"/1.2mm M6 Ecu
B2505-08	Contact Tip .030"/0.8mm M6 CuCrZr
B2505-09	Contact Tip .035"/0.9mm M6 CuCrZr
B2505-10	Contact Tip .040"/1.0mm M6 CuCrZr
B2505-12	Contact Tip .045"/1.2mm M6 CuCrZr

Liners	
Stock Code	Description
C B1535-30	Steel Liner .023"-.035"/0.6-0.9mm x 3mt
B1535-40	Steel Liner .023"-.035"/0.6-0.9mm x 4mt
B1535-50	Steel Liner .023"-.035"/0.6-0.9mm x 5mt
B2524-30*	Steel Liner .040"-.045"/1.0-1.2mm x 3mt
B2524-40*	Steel Liner .040"-.045"/1.0-1.2mm x 4mt
B2524-50*	Steel Liner .040"-.045"/1.0-1.2mm x 5mt
B1536-30	Teflon Liner .023"-.035"/0.6-0.9mm x 3mt
B1536-40	Teflon Liner .023"-.035"/0.6-0.9mm x 4mt
B1536-50	Teflon Liner .023"-.035"/0.6-0.9mm x 5mt

Liners (continued)	
Stock Code	Description
B2513-30	Teflon Liner .040"-.045"/1.0-1.2mm x 3mt
B2513-40	Teflon Liner .040"-.045"/1.0-1.2mm x 4mt
B2513-50	Teflon Liner .040"-.045"/1.0-1.2mm x 5mt

Components		
Stock Code	Description	* Denotes Standard Build
1 B2412	Tip Adaptor	
2 B2405B	Diffuser Black	
B2405C*	Diffuser Ceramic	
B2405W	Diffuser White	
3 B2401	Swan Neck	
4 B1515/ER	Ergo Handle Location Body	
5 B1505	Lock Nut	
6 B8011	Cable Support c/w Knuckle Joint	
7 B1521	Cable Terminal	
8 B2514	Ergo Handle Kit c/w Lock Nut	
9 B2516	Ergo Trigger	
10 B2517	Hanger Hook	
11 B2603-30	Hyperflex Cable Assembly x 3mt	
B2603-40	Hyperflex Cable Assembly x 4mt	
B2603-50	Hyperflex Cable Assembly x 5mt	
12 B1522	Cable Terminal Male	
13 B2841	Cable Support	
14 B1518	Gun Plug Housing c/w Nut	
15 B1526	Gun Plug Screw	
16 B1519	Gun Plug Nut c/w Insert	
17 Spring Pin 2	Spring Pin Assembly	
18 B1528	Gun Plug Body c/w Spring Pins	
19 B1524	Gun Plug 'O' Ring	
20 B1525	Liner Nut	

# SB 250A

## Air Cooled MIG Welding Torch

Rating: 230A CO<sub>2</sub> 200 A mixed gas @ 60% duty cycle, EN60974-7. .030"-.045"/0.8mm-1.2mm wires

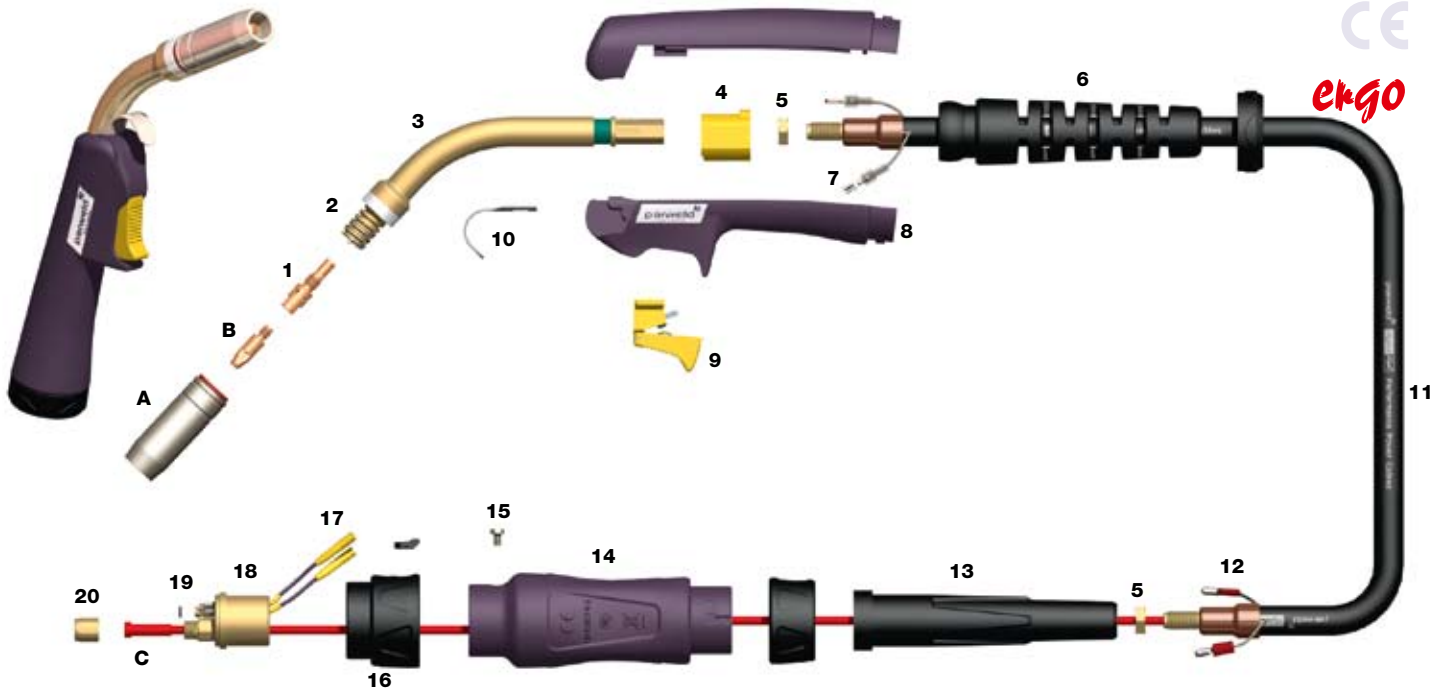

Model				
Stock Code	3M	4M	5M	Model Description
B2500	-30ER	-40ER	-50ER	Welding Torch c/w Ergo Handle
B2500	-30EB	-40EB	-50EB	Welding Torch c/w Bladeswitch Handle
B2500	-30EM	-40EM	-50EM	Welding Torch c/w Microswitch Handle

Nozzles	
Stock Code	Description
A B2507	Cylindrical Nozzle 1 1/16"/18mm Bore
B2508*	Conical Nozzle 19/32"/15mm Bore
B2509	Tapered Nozzle 15/32"/12mm Bore
B2510	Bottle Nozzle 19/32"/15mm Bore
B2511	Spot Welding Nozzle 1 1/16"/18mm Bore

Contact Tips	
Stock Code	Description
B B2504-08	Contact Tip .030"/0.8mm M6 Ecu
B2504-09	Contact Tip .035"/0.9mm M6 Ecu
B2504-10*	Contact Tip .040"/1.0mm M6 Ecu
B2504-12	Contact Tip .045"/1.2mm M6 Ecu
B2505-08	Contact Tip .030"/0.8mm M6 CuCrZr
B2505-09	Contact Tip .035"/0.9mm M6 CuCrZr
B2505-10	Contact Tip .040"/1.0mm M6 CuCrZr
B2505-12	Contact Tip .045"/1.2mm M6 CuCrZr

Liners	
Stock Code	Description
C B1535-30	Steel Liner .023"-.035"/0.6-0.9mm x 3mt
B1535-40	Steel Liner .023"-.035"/0.6-0.9mm x 4mt
B1535-50	Steel Liner .023"-.035"/0.6-0.9mm x 5mt
B2524-30*	Steel Liner .040"-.045"/1.0-1.2mm x 3mt
B2524-40*	Steel Liner .040"-.045"/1.0-1.2mm x 4mt
B2524-50*	Steel Liner .040"-.045"/1.0-1.2mm x 5mt
B1536-30	Teflon Liner .023"-.035"/0.6-0.9mm x 3mt
B1536-40	Teflon Liner .023"-.035"/0.6-0.9mm x 4mt
B1536-50	Teflon Liner .023"-.035"/0.6-0.9mm x 5mt
B2513-30	Teflon Liner .040"-.045"/1.0-1.2mm x 3mt
B2513-40	Teflon Liner .040"-.045"/1.0-1.2mm x 4mt
B2513-50	Teflon Liner .040"-.045"/1.0-1.2mm x 5mt

Components		
Stock Code	Description	* Denotes Standard Build
1	B2506*	Tip Adaptor M6
NI	B2536	Tip Adaptor M8 – See M8 Tips shown on Page 31
2	B2502	Shroud Spring
3	B2501	Swan Neck
4	B1515/ER	Ergo Handle Location Body
5	B1505	Lock Nut
6	B8015	Cable Support c/w Knuckle Joint
7	B1521	Cable Terminal
8	B2514	Ergo Handle Kit c/w Lock Nut
9	B2516	Ergo Trigger
10	B2517	Hanger Hook
11	B2503-30	Hyperflex Cable Assembly x 3mt
	B2503-40	Hyperflex Cable Assembly x 4mt
	B2503-50	Hyperflex Cable Assembly x 5mt
12	B1522	Cable Terminal Male
13	B2841	Cable Support
14	B1518	Gun Plug Housing c/w Nut
15	B1526	Gun Plug Screw
16	B1519	Gun Plug Nut c/w Insert
17	Spring Pin 2	Spring Pin Assembly
18	B1528	Gun Plug Body c/w Spring Pins
19	B1524	Gun Plug 'O' Ring
20	B1525	Liner Nut

# SB 250A FLEX

## Air Cooled MIG Welding Torch

Rating: 230A CO2 200A mixed gas @ 60% duty cycle, EN60974-7. .030"-.045"/0.8mm-1.2mm wires

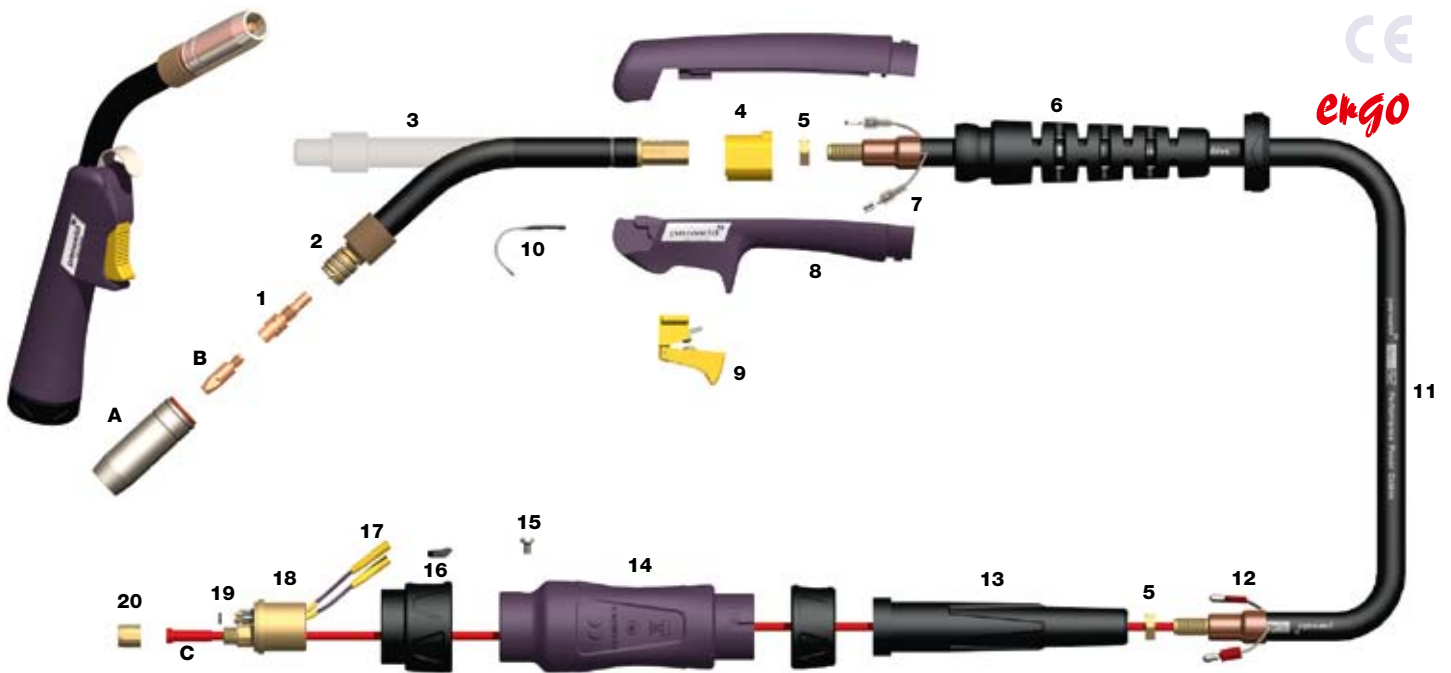

Model	3M	4M	Model Description
Stock Code	3M	4M	Model Description
B2500FX	-30ER	-40ER	Welding Torch c/w Euro Fitting

Nozzles	
Stock Code	Description
<b>A</b> B2507	Cylindrical Nozzle 1 1/16"/18mm Bore
B2508*	Conical Nozzle 19/32"/15mm Bore
B2509	Tapered Nozzle 15/32"/12mm Bore
B2510	Bottle Nozzle 19/32"/15mm Bore
B2511	Spot Welding Nozzle 1/16"/18mm Bore

Contact Tips	
Stock Code	Description
<b>B</b> B2504-08	Contact Tip .030"/0.8mm M6 Ecu
B2504-09	Contact Tip .035"/0.9mm M6 Ecu
B2504-10*	Contact Tip .040"/1.0mm M6 Ecu
B2504-12	Contact Tip .045"/1.2mm M6 Ecu
B2505-08	Contact Tip .030"/0.8mm M6 CuCrZr
B2505-09	Contact Tip .035"/0.9mm M6 CuCrZr
B2505-10	Contact Tip .040"/1.0mm M6 CuCrZr
B2505-12	Contact Tip .045"/1.2mm M6 CuCrZr

Liners	
Stock Code	Description
<b>C</b> B1535-30	Steel Liner .023"-.035"/0.6-0.9mm x 3mt
B1535-40	Steel Liner .023"-.035"/0.6-0.9mm x 4mt
B2524-30*	Steel Liner .040"-.045"/1.0-1.2mm x 3mt
B2524-40*	Steel Liner .040"-.045"/1.0-1.2mm x 4mt
B1536-30	Teflon Liner .023"-.035"/0.6-0.9mm x 3mt
B1536-40	Teflon Liner .023"-.035"/0.6-0.9mm x 4mt
B2513-30	Teflon Liner .040"-.045"/1.0-1.2mm x 3mt
B2513-40	Teflon Liner .040"-.045"/1.0-1.2mm x 4mt

Components		
Stock Code	Description	* Denotes Standard Build
<b>1</b> B2506*	Tip Adaptor M6	
<b>NI</b> B2536	Tip Adaptor M8 – See M8 Tips shown on Page 31	
<b>2</b> B2502	Shroud Spring	
<b>3</b> B2501FX	Swan Neck	
<b>4</b> B1515/ER	Handle Location Body	
<b>5</b> B1505	Lock Nut	
<b>6</b> B8011	Cable Support c/w Knuckle Joint	
<b>7</b> B1521	Cable Terminal	
<b>8</b> B2514	Ergo Handle Kit c/w Lock Nut	
<b>9</b> B2516	Ergo Trigger	
<b>10</b> B2517	Hanger Hook	
<b>11</b> B2503-30	Hyperflex Cable Assembly x 3mt	
B2503-40	Hyperflex Cable Assembly x 4mt	
<b>12</b> B1522	Cable Terminal Male	
<b>13</b> B2841	Cable Support	
<b>14</b> B1518	Gun Plug Housing c/w Nut	
<b>15</b> B1526	Gun Plug Screw	
<b>16</b> B1519	Gun Plug Nut c/w Insert	
<b>17</b> Spring Pin 2	Spring Pin Assembly	
<b>18</b> B1528	Gun Plug Body c/w Spring Pins	
<b>19</b> B1524	Gun Plug 'O' Ring	
<b>20</b> B1525	Liner Nut	

NI Not Illustrated.

# SB 260A

## Air Cooled MIG Welding Torch

Rating: 250A CO<sub>2</sub> 220A mixed gas @ 60% duty cycle, EN60974-7. .030"-.045"/0.8mm-1.2mm wires

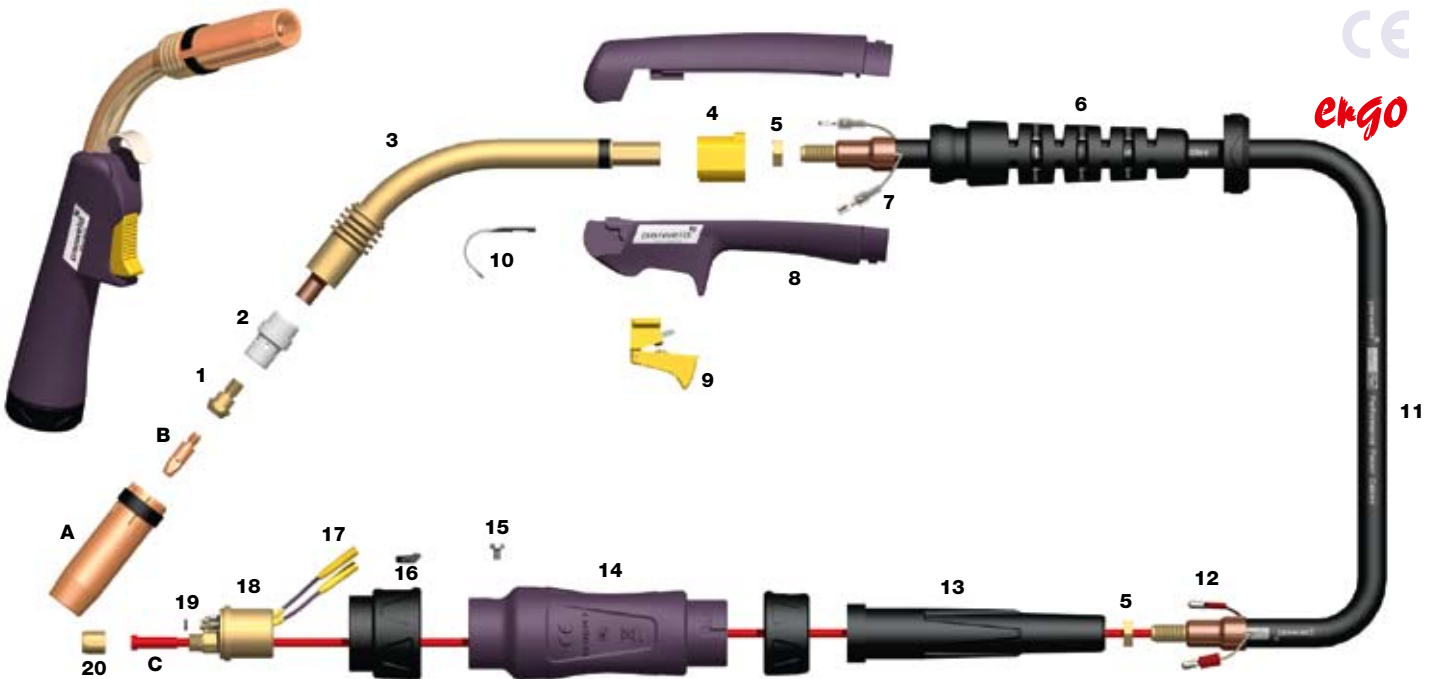

Model				
Stock Code	3M	4M	5M	Model Description
B2600	-30ER	-40ER	-50ER	Welding Torch c/w Ergo Handle
B2600	-30EB	-40EB	-50EB	Welding Torch c/w Bladeswitch Handle
B2600	-30EM	-40EM	-50EM	Welding Torch c/w Microswitch Handle

Nozzles	
Stock Code	Description
<b>A</b> B5027	Cylindrical Nozzle 3/4"/19mm Bore
B5028*	Conical Nozzle 5/8"/16mm Bore
B5029	Tapered Nozzle 9/16"/14mm Bore

Contact Tips	
Stock Code	Description
<b>B</b> B2504-08	Contact Tip .030"/0.8mm M6 Ecu
B2504-09	Contact Tip .035"/0.9mm M6 Ecu
B2504-10	Contact Tip .040"/1.0mm M6 Ecu
B2504-12*	Contact Tip .045"/1.2mm M6 Ecu
B2505-08	Contact Tip .030"/0.8mm M6 CuCrZr
B2505-09	Contact Tip .035"/0.9mm M6 CuCrZr
B2505-10	Contact Tip .040"/1.0mm M6 CuCrZr
B2505-12	Contact Tip .045"/1.2mm M6 CuCrZr

Liners	
Stock Code	Description
<b>C</b> B2524-30*	Steel Liner .040"-.045"/1.0-1.2mm x 3mt
B2524-40*	Steel Liner .040"-.045"/1.0-1.2mm x 4mt
B2524-50*	Steel Liner .040"-.045"/1.0-1.2mm x 5mt
B2513-30	Teflon Liner .040"-.045"/1.0-1.2mm x 3mt
B2513-40	Teflon Liner .040"-.045"/1.0-1.2mm x 4mt
B2513-50	Teflon Liner .040"-.045"/1.0-1.2mm x 5mt

Components		
Stock Code	Description	* Denotes Standard Build
<b>1</b> B2612	Tip Adaptor M6	
<b>NI</b> B2612M8	Tip Adaptor M8 – See M8 Tips shown on Page 31	
<b>2</b> B2605B	Diffuser Black	
B2605C*	Diffuser Ceramic	
B2605W	Diffuser White	
<b>3</b> B2601	Swan Neck	
<b>4</b> B1515/ER	Ergo Handle Location Body	
<b>5</b> B1505	Lock Nut	
<b>6</b> B8015	Cable Support c/w Knuckle Joint	
<b>7</b> B1521	Cable Terminal	
<b>8</b> B2514/KJ	Ergo Handle Kit c/w Lock Nut	
<b>9</b> B2516	Ergo Trigger	
<b>10</b> B2517	Hanger Hook	
<b>11</b> B2603-30	Hyperflex Cable Assembly x 3mt	
B2603-40	Hyperflex Cable Assembly x 4mt	
B2603-50	Hyperflex Cable Assembly x 5mt	
<b>12</b> B1522	Cable Terminal Male	
<b>13</b> B2841	Cable Support	
<b>14</b> B1518	Gun Plug Housing c/w Nut	
<b>15</b> B1526	Gun Plug Screw	
<b>16</b> B1519	Gun Plug Nut c/w Insert	
<b>17</b> Spring Pin 2	Spring Pin Assembly	
<b>18</b> B1528	Gun Plug Body c/w Spring Pins	
<b>19</b> B1524	Gun Plug 'O' Ring	
<b>20</b> B1525	Liner Nut	

NI Not Illustrated.

# SB 360A

## Air Cooled MIG Welding Torch

Rating: 300A CO<sub>2</sub> 270A mixed gas, EN60974-7 @ 60% duty cycle. .030"-.045"/0.8mm-1.2mm wires

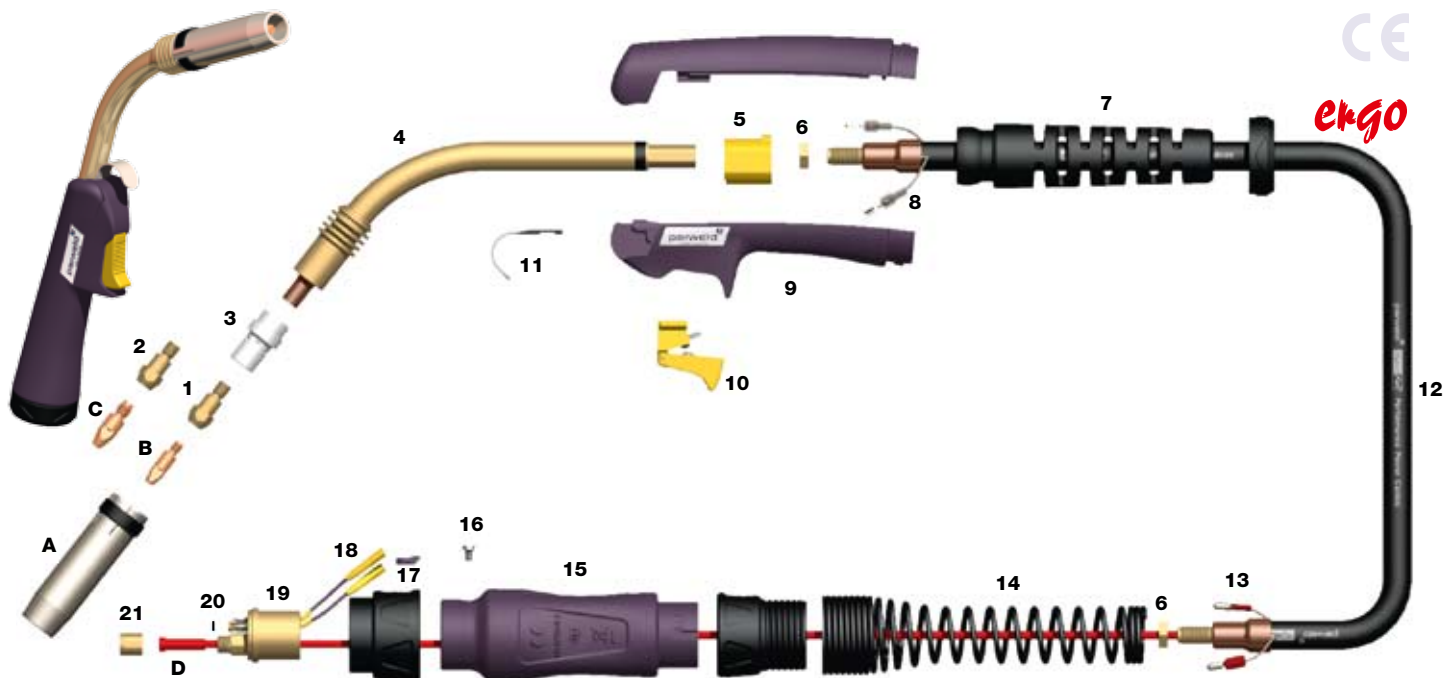

Model	3M	4M	5M	Model Description
B3600	-30ER	-40ER	-50ER	Welding Torch c/w Ergo Handle
B3600	-30EB	-40EB	-50EB	Welding Torch c/w Bladeswitch Handle
B3600	-30EM	-40EM	-50EM	Welding Torch c/w Microswitch Handle

Nozzles	
Stock Code	Description
A B3615	Cylindrical Nozzle 3/4"/19mm Bore
B3616*	Conical Nozzle 5/8"/16mm Bore
B3617	Tapered Nozzle 15/32"/12mm Bore

Contact Tips	
Stock Code	Description
B B2504-10	Contact Tip .040"/1.0mm M6 Ecu
B2504-12*	Contact Tip .045"/1.2mm M6 Ecu
B2505-10	Contact Tip .040"/1.0mm M6 CuCrZr
B2505-12	Contact Tip .045"/1.2mm M6 CuCrZr
C B4014-10	Contact Tip .040"/1.0mm M8 Ecu
B4014-12	Contact Tip .045"/1.2mm M8 Ecu
B4015-10	Contact Tip .040"/1.0mm M8 CuCrZr
B4015-12	Contact Tip .045"/1.2mm M8 CuCrZr

Liners	
Stock Code	Description
D B2524-30*	Steel Liner .040"-.045"/1.0-1.2mm x 3mt
B2524-40*	Steel Liner .040"-.045"/1.0-1.2mm x 4mt
B2524-50*	Steel Liner .040"-.045"/1.0-1.2mm x 5mt
B2513-30	Teflon Liner .040"-.045"/1.0-1.2mm x 3mt
B2513-40	Teflon Liner .040"-.045"/1.0-1.2mm x 4mt
B2513-50	Teflon Liner .040"-.045"/1.0-1.2mm x 5mt

Components		
Stock Code	Description	* Denotes Standard Build
1	B3612*	Tip Adaptor 28.5mm M6
2	B3614	Tip Adaptor 28.5mm M8
NI	B3613	Tip Adaptor 31.5mm M6
3	B3605B	Diffuser Black
	B3605C*	Diffuser Ceramic
	B3605W	Diffuser White
4	B3603	Swan Neck
5	B1515/ER	Ergo Handle Location Body
6	B1505	Lock Nut
7	B8016	Cable Support c/w Knuckle Joint
8	B1521	Cable Terminal
9	B2514	Ergo Handle Kit c/w Lock Nut
10	B2516	Ergo Trigger
11	B2517	Hanger Hook
12	B3609-30	Hyperflex Cable Assembly x 3mt
	B3609-40	Hyperflex Cable Assembly x 4mt
	B3609-50	Hyperflex Cable Assembly x 5mt
13	B1522	Cable Terminal Male
14	B8026	Spring Cable Support
15	B1518	Gun Plug Housing c/w Nut
16	B1526	Gun Plug Screw
17	B1519	Gun Plug Nut c/w insert
18	Spring Pin 2	Spring Pin Assembly
19	B1528	Gun Plug Body c/w Spring Pins
20	B1524	Gun Plug 'O' Ring
21	B1525	Liner Nut

NI Not Illustrated.



ergo

12

# SB 380A

## Air Cooled MIG Welding Torch

Rating: 350A CO2 320A mixed gas @ 60% duty cycle, EN60974-7. .045"-1/16"/1.2mm-1.6mm wires

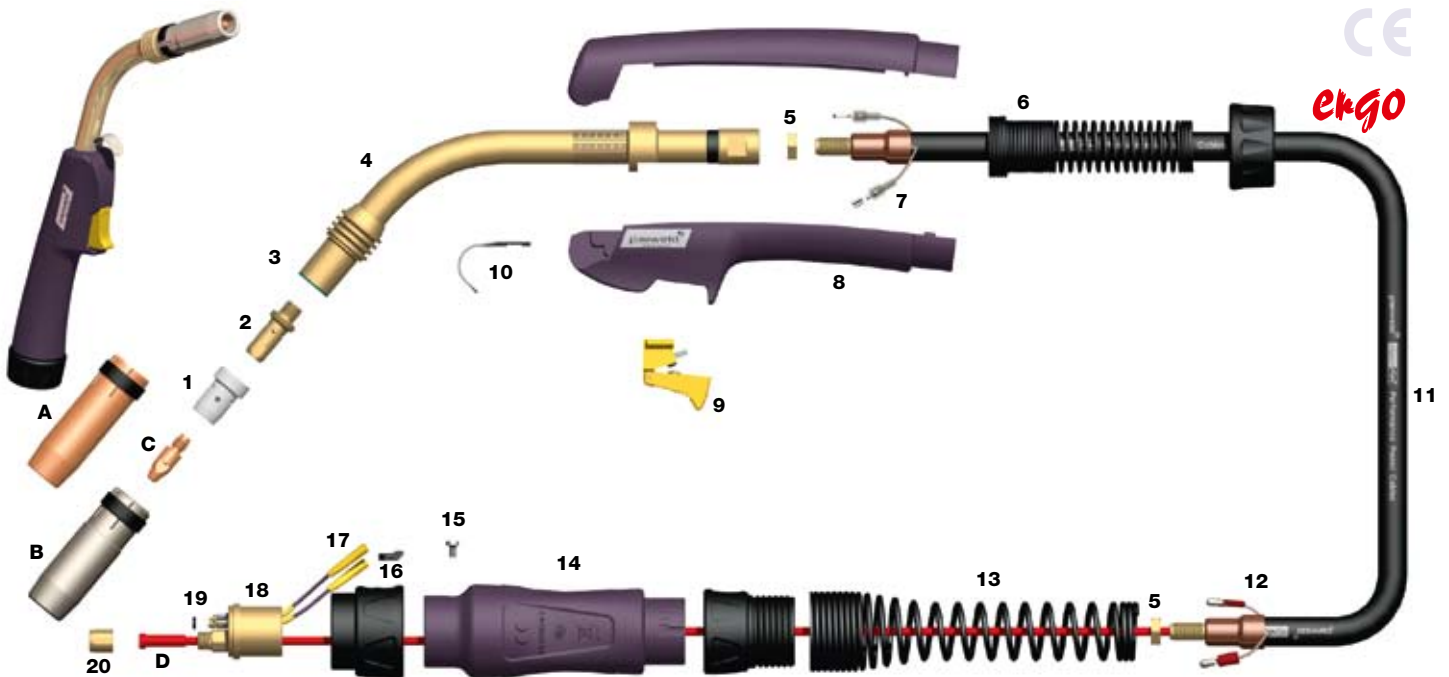

Model	3M	4M	5M	Model Description
Stock Code	3M	4M	5M	Model Description
B3800	-30ER	-40ER	-50ER	Welding Torch c/w Euro Fitting

Nozzles	
Stock Code	Description
<b>A</b> B5027	Cylindrical Nozzle 3/4"/19mm Bore
B5028	Conical Nozzle 5/8"/16mm Bore
B5029	Tapered Nozzle 9/16"/14mm Bore
<b>B</b> B5028HD*	Heavy Duty Conical Nozzle 5/8"/16mm Bore

Contact Tips	
Stock Code	Description
<b>C</b> B4014-12*	Contact Tip .045"/1.2mm M8 Ecu
B4014-16	Contact Tip 1/16"/1.6mm M8 Ecu
B4015-12	Contact Tip .045"/1.2mm M8 CuCrZr
B4015-16	Contact Tip 1/16"/1.6mm M8 CuCrZr

Liners	
Stock Code	Description
<b>D</b> B2524-30*	Steel Liner .040"- .045"/1.0-1.2mm x 3mt
B2524-40*	Steel Liner .040"- .045"/1.0-1.2mm x 4mt
B2524-50*	Steel Liner .040"- .045"/1.0-1.2mm x 5mt
B3631-30	Steel Liner 1/16"/1.6mm x 3mt
B3631-40	Steel Liner 1/16"/1.6mm x 4mt
B3631-50	Steel Liner 1/16"/1.6mm x 5mt
B2513-30	Teflon Liner .040"- .045"/1.0-1.2mm x 3mt
B2513-40	Teflon Liner .040"- .045"/1.0-1.2mm x 4mt
B2513-50	Teflon Liner .040"- .045"/1.0-1.2mm x 5mt
B3626-30	Teflon Liner .045"-1/16"/1.2mm-1.6mm x 3mt
B3626-40	Teflon Liner .045"-1/16"/1.2mm-1.6mm x 4mt
B3626-50	Teflon Liner .045"-1/16"/1.2mm-1.6mm x 5mt

Components		
Stock Code	Description	* Denotes Standard Build
<b>1</b> B5005B	Diffuser Black	
B5005C*	Diffuser Ceramic	
B5005W	Diffuser White	
<b>2</b> B3812	Tip Adaptor M8	
<b>3</b> B3803	Insulating Washer	
<b>4</b> B3801	Swan Neck	
<b>5</b> B1505	Lock Nut	
<b>6</b> B8019	Cable Spring Support	
<b>7</b> B1521	Cable Terminal	
<b>8</b> B4514	Ergo Handle c/w Lock Nut	
<b>9</b> B2516	Ergo Trigger	
<b>10</b> B2517	Hanger Hook	
<b>11</b> B3609-30	Hyperflex Cable Assembly x 3mt	
B3609-40	Hyperflex Cable Assembly x 4mt	
B3609-50	Hyperflex Cable Assembly x 5mt	
<b>12</b> B1522	Cable Terminal Male	
<b>13</b> B8026	Spring Cable Support	
<b>14</b> B1518	Gun Plug Housing c/w Nut	
<b>15</b> B1526	Gun Plug Screw	
<b>16</b> B1519	Gun Plug Nut c/w insert	
<b>17</b> Spring Pin 2	Spring Pin Assembly	
<b>18</b> B1528	Gun Plug Body c/w Spring Pins	
<b>19</b> B1524	Gun Plug 'O' Ring	
<b>20</b> B1525	Liner Nut	

# SB 400A

## Air Cooled MIG Welding Torch

Rating: 350A CO2 320A mixed gas @ 60% duty cycle, EN60974-7. .040"-3/32"/1.0mm-2.4mm wires

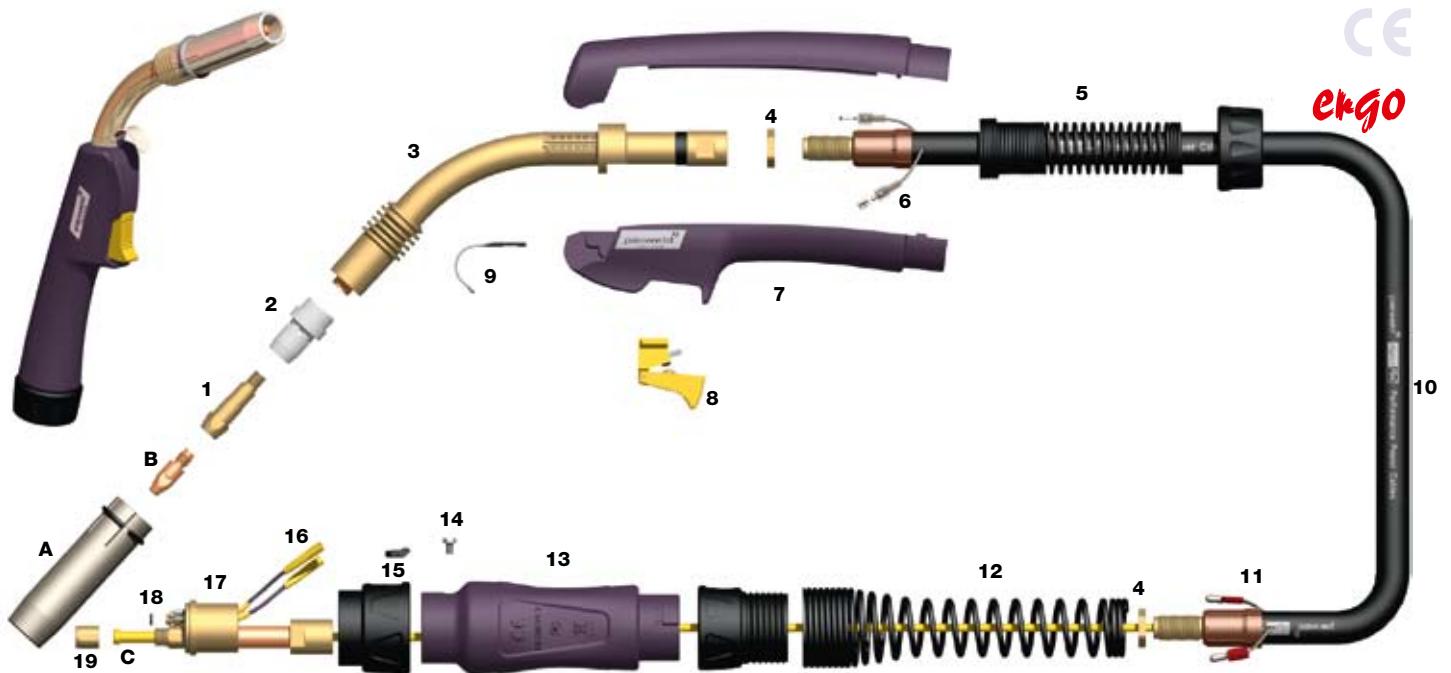

Model	3M	4M	5M	Model Description
Stock Code	3M	4M	5M	Model Description
B4000	-30ER	-40ER	-50ER	Welding Torch c/w Euro Fitting

Nozzles	Stock Code	Description
A	B4017*	Conical Nozzle 1 1/16"/18mm Bore

Contact Tips	Stock Code	Description
B	B4014-10	Contact Tip .040"/1.0mm M8 Ecu
	B4014-12*	Contact Tip .045"/1.2mm M8 Ecu
	B4014-16	Contact Tip 1/16"/1.6mm M8 Ecu
	B4014-20	Contact Tip .080"/2.0mm M8 Ecu
	B4014-24	Contact Tip .090"/2.4mm M8 Ecu
	B4015-10	Contact Tip .040"/1.0mm M8 CuCrZr
	B4015-12	Contact Tip .045"/1.2mm M8 CuCrZr
	B4015-16	Contact Tip 1/16"/1.6mm M8 CuCrZr
	B4015-24	Contact Tip .090"/2.4mm M8 CuCrZr

Liners	Stock Code	Description
C	B2524-30	Steel Liner .040"- .045"/1.0-1.2mm x 3mt
	B2524-40	Steel Liner .040"- .045"/1.0-1.2mm x 4mt
	B2524-50	Steel Liner .040"- .045"/1.0-1.2mm x 5mt
	B3631-30*	Steel Liner 1/16"/1.6mm x 3mt
	B3631-40*	Steel Liner 1/16"/1.6mm x 4mt
	B3631-50*	Steel Liner 1/16"/1.6mm x 5mt
	B4631-30	Steel Liner .080"- .090"/2.0-2.4mm x 3mt
	B4631-40	Steel Liner .080"- .090"/2.0-2.4mm x 4mt
	B4631-50	Steel Liner .080"- .090"/2.0-2.4mm x 5mt
	B2513-30	Teflon Liner .040"- .045"/1.0-1.2mm x 3mt
	B2513-40	Teflon Liner .040"- .045"/1.0-1.2mm x 4mt
	B2513-50	Teflon Liner .040"- .045"/1.0-1.2mm x 5mt

Components	Stock Code	Description	* Denotes Standard Build
1	B4005	Tip Adaptor	
2	B4003B	Diffuser Black	
	B4003C*	Diffuser Ceramic	
3	B4002	Swan Neck	
4	B4050	Lock Nut	
5	B8019	Cable Spring Support	
6	B1521	Cable Terminal	
7	B4514	Ergo Handle c/w Lock Nut	
8	B2516	Ergo Trigger	
9	B2517	Hanger Hook	
10	B4010-30	Hyperflex Cable Assembly x 3mt	
	B4010-40	Hyperflex Cable Assembly x 4mt	
	B4010-50	Hyperflex Cable Assembly x 5mt	
11	B1522	Cable Terminal Male	
12	B8026	Spring Cable Support	
13	B1518	Gun Plug Housing c/w Nut	
14	B1526	Gun Plug Screw	
15	B1519	Gun Plug Nut c/w insert	
16	Spring Pin 2	Spring Pin Assembly	
17	B4038	Gun Plug Body c/w Spring Pins	
18	B1524	Gun Plug 'O' Ring	
19	B1525	Liner Nut	

# SB 240W

## Water Cooled MIG Welding Torch

Rating: 300A CO<sub>2</sub> 270A mixed gas @ 100% duty cycle, EN60974-7. .030"-.045"/0.8 to 1.2mm wires

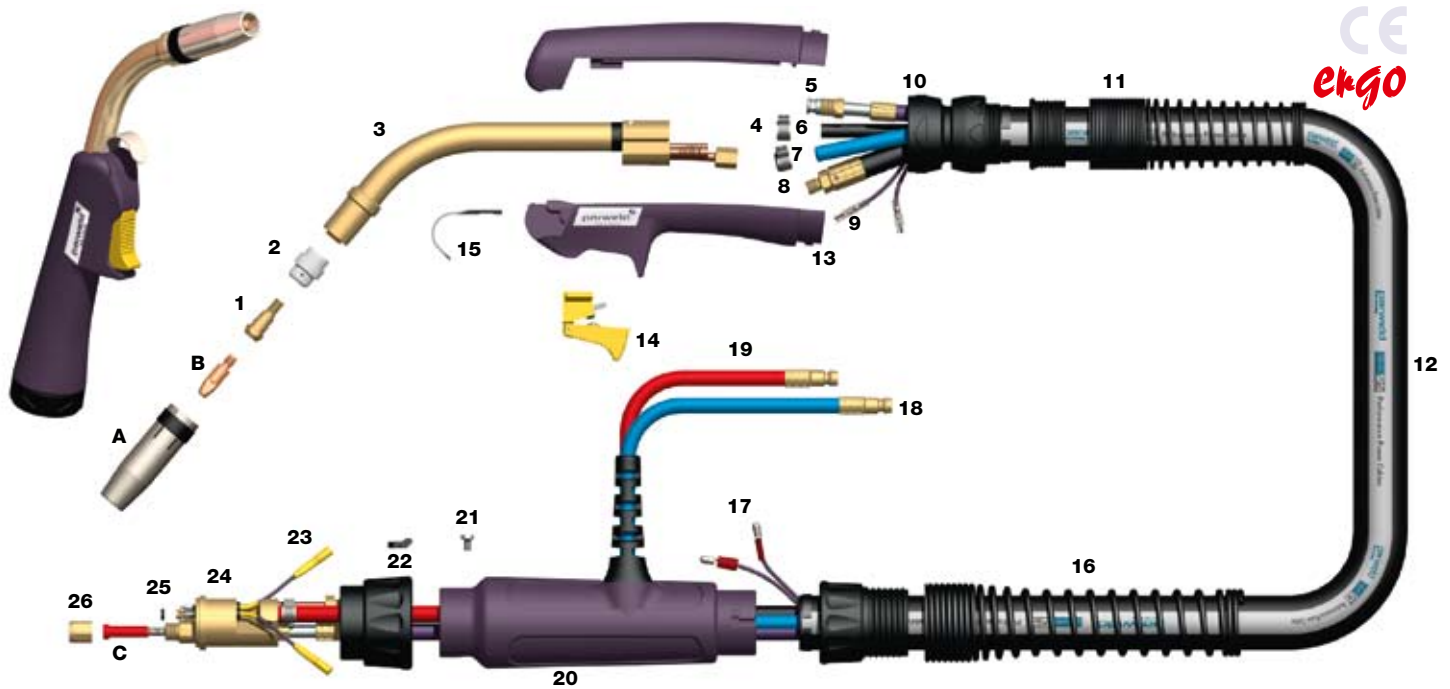

Model	3M	4M	5M	Model Description
B2400W	-30ER	-40ER	-50ER	Welding Torch c/w Ergo Handle
B2400W	-30EB	-40EB	-50EB	Welding Torch c/w Bladeswitch Handle
B2400W	-30EM	-40EM	-50EM	Welding Torch c/w Microswitch Handle

Nozzles	
Stock Code	Description
<b>A</b> B2415	Cylindrical Nozzle 43/64"/17mm Bore
B2416*	Conical Nozzle 1/2"/13mm Bore
B2417	Tapered Nozzle 3/8"/10mm Bore

Contact Tips	
Stock Code	Description
<b>B</b> B2504-08	Contact Tip .030"/0.8mm M6 Ecu
B2504-09	Contact Tip .035"/0.9mm M6 Ecu
B2504-10*	Contact Tip .040"/1.0mm M6 Ecu
B2504-12	Contact Tip .045"/1.2mm M6 Ecu
B2505-08	Contact Tip .030"/0.8mm M6 CuCrZr
B2505-09	Contact Tip .035"/0.9mm M6 CuCrZr
B2505-10	Contact Tip .040"/1.0mm M6 CuCrZr
B2505-12	Contact Tip .045"/1.2mm M6 CuCrZr

Liners	
Stock Code	Description
<b>C</b> B5033-30*	Plain Liner .040"-.045"/1.0-1.2mm x 3mt
B5033-40*	Plain Liner .040"-.045"/1.0-1.2mm x 4mt
B5033-50*	Plain Liner .040"-.045"/1.0-1.2mm x 5mt
B1536-30	Teflon Liner .030"-.035"/0.6-0.9mm x 3mt
B1536-40	Teflon Liner .030"-.035"/0.6-0.9mm x 4mt
B1536-50	Teflon Liner .030"-.035"/0.6-0.9mm x 5mt
B2513-30	Teflon Liner .040"-.045"/1.0-1.2mm x 3mt
B2513-40	Teflon Liner .040"-.045"/1.0-1.2mm x 4mt

Components		
Stock Code	Description	* Denotes Standard Build
<b>1</b> B2412	Tip Adaptor	
<b>2</b> B2405B	Diffuser Black	
B2405C*	Diffuser Ceramic	
B2405W	Diffuser White	
<b>3</b> B2409	Swan Neck	
<b>4</b> B5024	Water Hose Clamp 9.5mm	
<b>10</b> B8031	Ball Joint Assembly c/w Clamp	
<b>11</b> B8032	Spring Cable Support c/w Adaptor	
<b>13</b> B2514	Ergo Handle	
<b>14</b> B2516	Ergo Trigger	
<b>15</b> B2517	Hanger Hook	
<b>16</b> B8027	Spring Cable Support	
<b>17</b> B1522	Cable Terminal Male	
<b>18</b> B5023	Water Hose Nipple	
<b>19</b> B5017	Water Outlet Hose O/Braid	
<b>20</b> B5022	Gun Plug Housing c/w Lock Nut and Hose Supports	
<b>21</b> B1526	Gun Plug Screw	
<b>22</b> B1519	Gun Plug Nut c/w insert	
<b>23</b> Spring Pin 2	Spring Pin Assembly	
<b>24</b> B5098	Gun Plug Body c/w Spring Pins	
<b>25</b> B1524	Gun Plug 'O' Ring	
<b>26</b> B1525	Liner Nut	

Components					
Stock Code	3M	4M	5M	Model Description	
<b>5</b> B5008	-30	-40	-50	Outer Liner Assembly	
<b>6</b> B5013	-30	-40	-50	Gas Hose Assembly	
<b>7</b> B5012	-30	-40	-50	Water Inlet Hose Assembly	
<b>8</b> B5015	-30	-40	-50	Power Cable Assembly	
<b>9</b> B5010	-30	-40	-50	Switch Lead Assembly	
<b>12</b> B5019	-30	-40	-50	Canvas Cover Assembly	

# SB 350W

## Water Cooled MIG Welding Torch

Rating: 320A CO2 280A mixed gas @ 100% duty cycle, EN60974-7. .030"- .045"/0.8mm-1.2mm wires

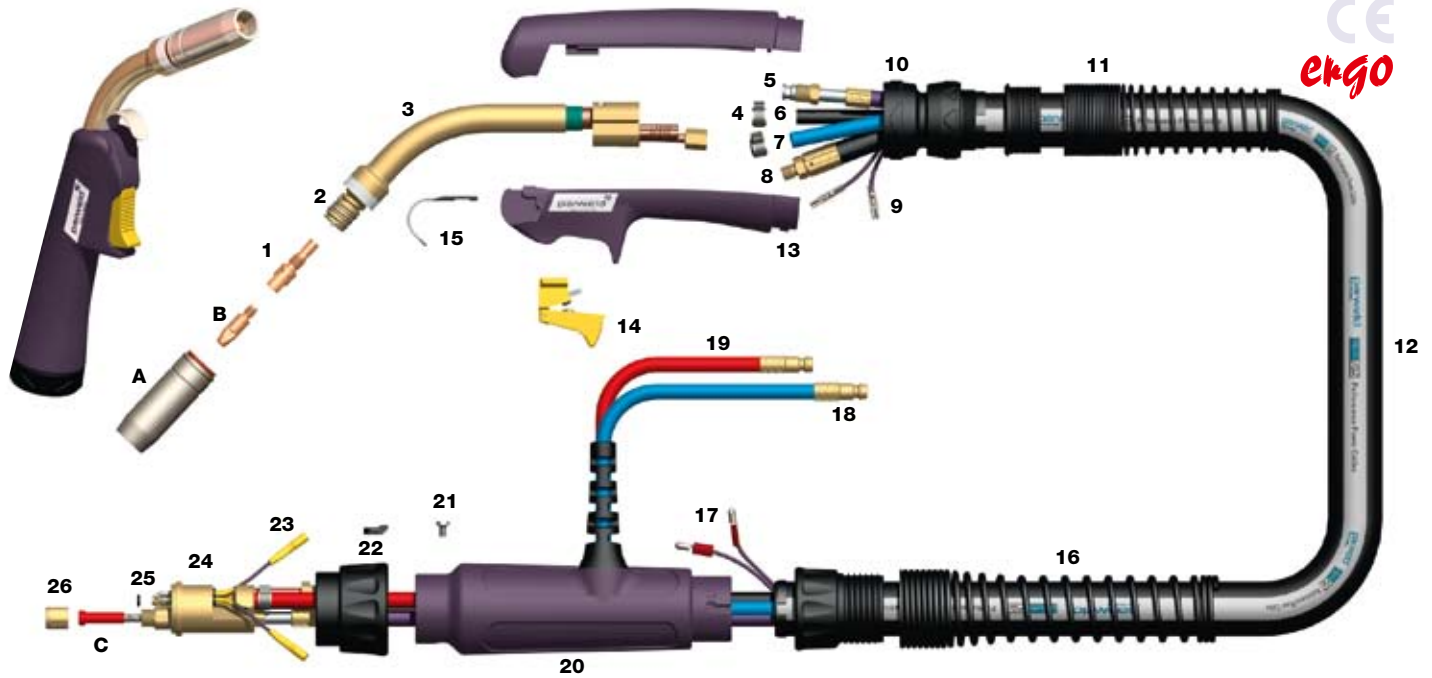

Model				
Stock Code	3M	4M	5M	Model Description
B3500	-30ER-40ER-50ER			Welding Torch c/w Ergo Handle
B3500	-30EB -40EB -50EB			Welding Torch c/w Bladeswitch Handle
3500	-30EM-40EM -50EM			Welding Torch c/w Microswitch Handle

Nozzles	
Stock Code	Description
<b>A</b> B2507	Cylindrical Nozzle 1 1/16"/18mm Bore
B2508*	Conical Nozzle 19/32"/15mm Bore
B2509	Tapered Nozzle 15/32"/12mm Bore

Contact Tips	
Stock Code	Description
<b>B</b> B2504-08	Contact Tip .030"/0.8mm M6 Ecu
B2504-09	Contact Tip .035"/0.9mm M6 Ecu
B2504-10*	Contact Tip .040"/1.0mm M6 Ecu
B2505-08	Contact Tip .030"/0.8mm M6 CuCrZr
B2505-09	Contact Tip .035"/0.9mm M6 CuCrZr
B2505-10	Contact Tip .040"/1.0mm M6 CuCrZr
B2505-12	Contact Tip .045"/1.2mm M6 CuCrZr

Liners	
Stock Code	Description
<b>C</b> B5033-30*	Plain Liner .040"- .045"/1.0-1.2mm x 3mt
B5033-40*	Plain Liner .040"- .045"/1.0-1.2mm x 4mt
B5033-50*	Plain Liner .040"- .045"/1.0-1.2mm x 5mt
B1536-30	Teflon Liner .030"- .035"/0.6-0.9mm x 3mt
B1536-40	Teflon Liner .030"- .035"/0.6-0.9mm x 4mt
B1536-50	Teflon Liner .030"- .035"/0.6-0.9mm x 5mt
B2513-30	Teflon Liner .040"- .045"/1.0-1.2mm x 3mt
B2513-40	Teflon Liner .040"- .045"/1.0-1.2mm x 4mt

Components			
Stock Code	Description	* Denotes Standard Build	
<b>1</b> B2506	Tip Adaptor		
<b>2</b> B2502	Shroud Spring		
<b>3</b> B3501	Swan Neck		
<b>4</b> B5024	Water Hose Clamp 9.5mm		
<b>10</b> B8031	Ball Joint Assembly c/w Clamp		
<b>11</b> B8032	Spring Cable Support c/w Adaptor		
<b>13</b> B2514	Ergo Handle		
<b>14</b> B2516	Ergo Trigger		
<b>15</b> B2517	Hanger Hook		
<b>16</b> B8027	Spring Support		
<b>17</b> B1522	Cable Terminal Male		
<b>18</b> B5023	Water Hose Nipple		
<b>19</b> B5017	Water Outlet Hose O/Braid		
<b>20</b> B5022	Gun Plug Housing c/w Lock Nut and Hose Supports		
<b>21</b> B1526	Gun Plug Screw		
<b>22</b> B1519	Gun Plug Nut c/w insert		
<b>23</b> Spring Pin 2	Spring Pin Assembly		
<b>24</b> B5098	Gun Plug Body c/w Spring Pins		
<b>25</b> B1524	Gun Plug 'O' Ring		
<b>26</b> B1525	Liner Nut		

Cable Assembly					
Stock Code	3M	4M	5M	Model Description	
<b>5</b> B5008	-30	-40	-50	Outer Liner Assembly	
<b>6</b> B5013	-30	-40	-50	Gas Hose Assembly	
<b>7</b> B5012	-30	-40	-50	Water Inlet Hose Assembly	
<b>8</b> B5015	-30	-40	-50	Power Cable Assembly	
<b>9</b> B5010	-30	-40	-50	Switch Lead Assembly	
<b>12</b> B5019	-30	-40	-50	Canvas Cover Assembly	

# SB 401W

## Water Cooled MIG Welding Torch

Rating: 400A CO2 350A mixed gas @ 100% duty cycle, EN60974-7. .030"-.045"/0.8mm-1.2mm wires

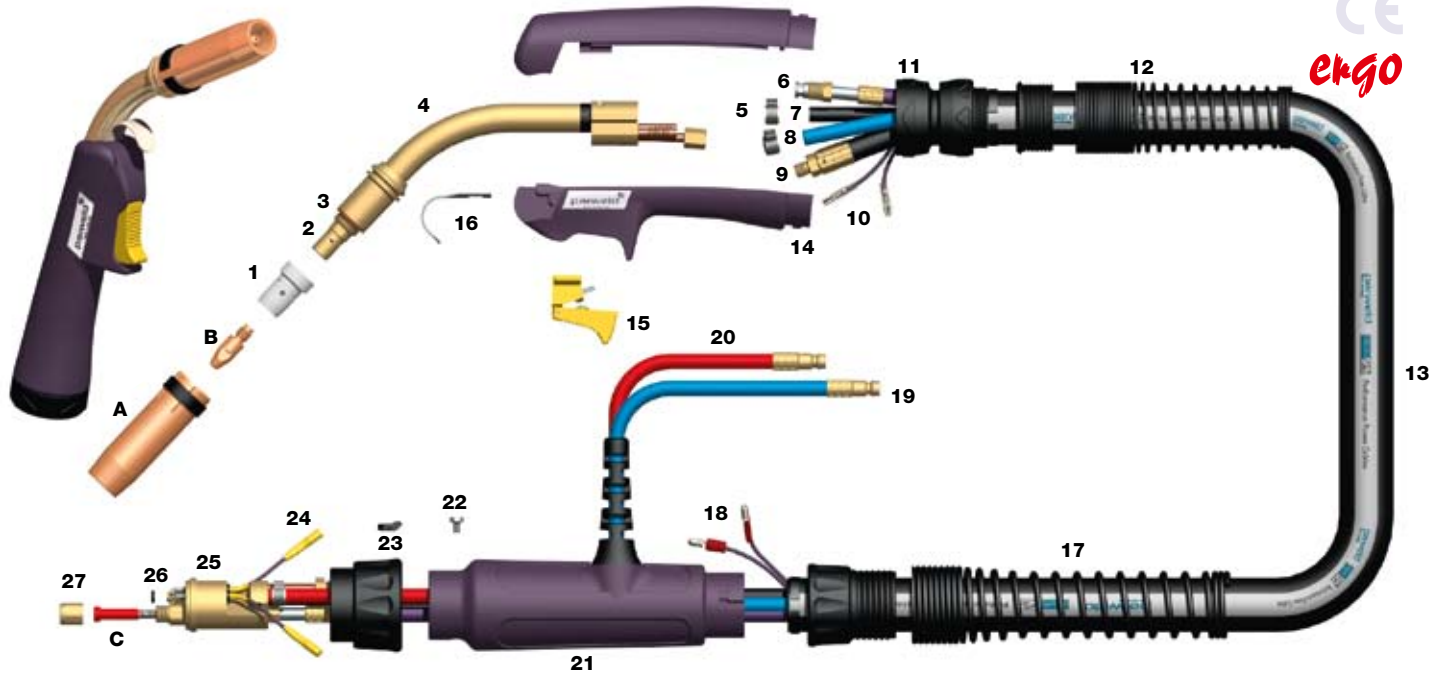

Model				
Stock Code	3M	4M	5M	Model Description
B4001	-30ER	-40ER	-50ER	Welding Torch c/w Ergo Handle
B4001	-30EB	-40EB	-50EB	Welding Torch c/w Bladeswitch Handle
B4001	-30EM	-40EM	-50EM	Welding Torch c/w Microswitch Handle

Nozzles	
Stock Code	Description
A B5027	Cylindrical Nozzle 3/4"/19mm Bore
B5028*	Conical Nozzle 5/8"/16mm Bore
B5029	Tapered Nozzle 9/16"/14mm Bore

Contact Tips	
Stock Code	Description
B B4014-08	Contact Tip .030"/0.8mm M8 Ecu
B4014-10	Contact Tip .040"/1.0mm M8 Ecu
B4014-12*	Contact Tip .045"/1.2mm M8 Ecu
B4015-10	Contact Tip .040"/1.0mm M8 CuCrZr
B4015-12	Contact Tip .045"/1.2mm M8 CuCrZr

Liners	
Stock Code	Description
C B5033-30*	Plain Liner .040"-.045"/1.0-1.2mm x 3mt
B5033-40*	Plain Liner .040"-.045"/1.0-1.2mm x 4mt
B5033-50*	Plain Liner .040"-.045"/1.0-1.2mm x 5mt
B2513-30	Teflon Liner .040"-.045"/1.0-1.2mm x 3mt
B2513-40	Teflon Liner .040"-.045"/1.0-1.2mm x 4mt
B2513-50	Teflon Liner .040"-.045"/1.0-1.2mm x 5mt

Components			
Stock Code	Description	* Denotes Standard Build	
1	B5005B	Diffuser Black	
	B5005C*	Diffuser Ceramic	
	B5005W	Diffuser White	
2	B5001	Tip Adaptor 25.0mm M8	
3	B5003	Insulating Washer	
4	B4011	Swan Neck	
5	B5024	Water Hose Clamp 9.5mm	
11	B8031	Ball Joint Assembly c/w Clamp	
12	B8032	Spring Cable Support c/w Adaptor	
14	B2514	Ergo Handle	
15	B2516	Ergo Trigger	
16	B2517	Hanger Hook	
17	B8027	Spring Cable Support	
18	B1522	Cable Terminal Male	
19	B5023	Water Hose Nipple	
20	B5017	Water Outlet Hose O/Braid	
21	B5022	Gun Plug Housing c/w Lock Nut and Hose Supports	
22	B1526	Gun Plug Screw	
23	B1519	Gun Plug Nut c/w Insert	
24	Spring Pin 2	Spring Pin Assembly	
25	B5098	Gun Plug Body c/w Spring Pins	
26	B1524	Gun Plug 'O' Ring	
27	B1525	Liner Nut	

Cable Assembly					
Stock Code	3M	4M	5M	Model Description	
6	B5008	-30	-40	-50	Outer Liner Assembly
7	B5013	-30	-40	-50	Gas Hose Assembly
8	B5012	-30	-40	-50	Water Inlet Hose Assembly
9	B5015	-30	-40	-50	Power Cable Assembly
10	B5010	-30	-40	-50	Switch Lead Assembly
13	B5019	-30	-40	-50	Canvas Cover Assembly

# SB 501W

## Water Cooled MIG Welding Torch

Rating: 520A CO2 430A mixed gas @ 100% duty cycle, EN60974-7. .040"-1/16"/1.0mm-1.6mm wires

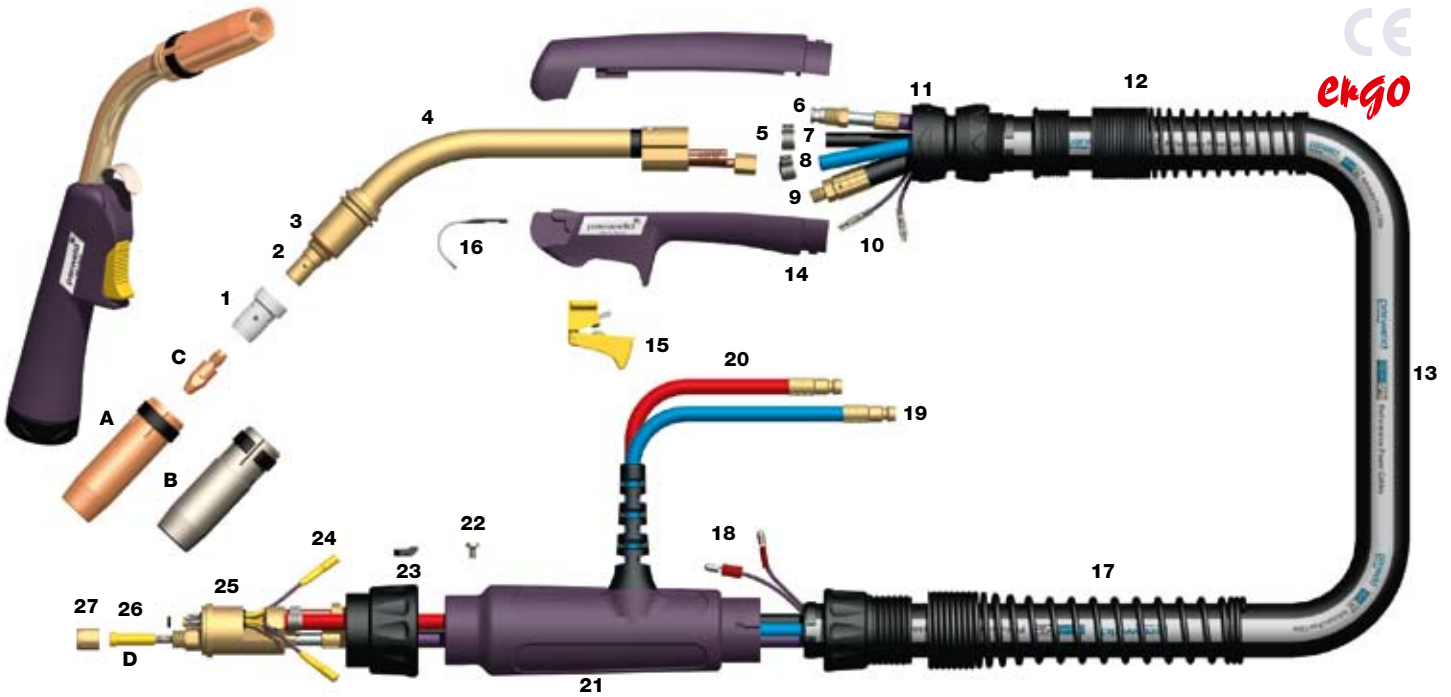

Model	3M	4M	5M	Model Description
B5000	-30ER	-40ER	-50ER	Welding Torch c/w Ergo Handle
B5000	-30EB	-40EB	-50EB	Welding Torch c/w Bladeswitch Handle
B5000	-30EM	-40EM	-50EM	Welding Torch c/w Microswitch Handle

Nozzles	
Stock Code	Description
<b>A</b> B5027	Cylindrical Nozzle 3/4"/19mm Bore
B5028*	Conical Nozzle 5/8"/16mm Bore
B5029	Tapered Nozzle 9/16"/14mm Bore
<b>B</b> B5028HD	Heavy Duty Conical Nozzle 5/8"/16mm Bore

Contact Tips	
Stock Code	Description
<b>C</b> B4014-10	Contact Tip .040"/1.0mm M8 Ecu
B4014-12*	Contact Tip .045"/1.2mm M8 Ecu
B4014-16	Contact Tip 1/16"/1.6mm M8 Ecu
B4015-10	Contact Tip .040"/1.0mm M8 CuCrZr
B4015-12	Contact Tip .045"/1.2mm M8 CuCrZr
B4015-16	Contact Tip 1/16"/1.6mm M8 CuCrZr

Liners	
Stock Code	Description
<b>D</b> B5033-30	Plain Liner .040"- .045"/1.0-1.2mm x 3mt
B5033-40	Plain Liner .040"- .045"/1.0-1.2mm x 4mt
B5033-50	Plain Liner .040"- .045"/1.0-1.2mm x 5mt
B5034-30*	Plain Liner .045"-1/16"/1.2-1.6mm x 3mt
B5034-40*	Plain Liner .045"-1/16"/1.2-1.6mm x 4mt
B5034-50*	Plain Liner .045"-1/16"/1.2-1.6mm x 5mt
B2513-30	Teflon Liner .040"- .045"/1.0-1.2mm x 3mt
B2513-40	Teflon Liner .040"- .045"/1.0-1.2mm x 4mt
B2513-50	Teflon Liner .040"- .045"/1.0-1.2mm x 5mt
B3626-30	Teflon Liner .045"-1/16"/1.2-1.6mm x 3mt
B3626-40	Teflon Liner .045"-1/16"/1.2-1.6mm x 4mt
B3626-50	Teflon Liner .045"-1/16"/1.2-1.6mm x 5mt

Components			
Stock Code	Description	* Denotes Standard Build	
<b>1</b> B5005B	Diffuser Black		
B5005C*	Diffuser Ceramic		
B5005W	Diffuser White		
<b>2</b> B5001	Tip Adaptor 25.0mm M8		
<b>3</b> B5003	Insulating Washer		
<b>4</b> B5002	Swan Neck		
<b>5</b> B5024	Water Hose Clamp 9.5mm		
<b>11</b> B8031	Ball Joint Assembly c/w Clamp		
<b>12</b> B8032	Spring Cable Support c/w Adaptor		
<b>14</b> B2514	Ergo Handle		
<b>15</b> B2516	Ergo Trigger		
<b>16</b> B2517	Hanger Hook		
<b>17</b> B8027	Spring Cable Support		
<b>18</b> B1522	Cable Terminal Male		
<b>19</b> B5023	Water Hose Nipple		
<b>20</b> B5017	Water Outlet Hose O/Braid		
<b>21</b> B5022	Gun Plug Housing c/w Lock Nut and Hose Supports		
<b>22</b> B1526	Gun Plug Screw		
<b>23</b> B1519	Gun Plug Nut c/w Insert		
<b>24</b> Spring Pin 2	Spring Pin Assembly		
<b>25</b> B5098	Gun Plug Body c/w Spring Pins		
<b>26</b> B1524	Gun Plug 'O' Ring		
<b>27</b> B1525	Liner Nut		

Cable Assembly					
Stock Code	3M	4M	5M	Model Description	
<b>6</b> B5008	-30	-40	-50	Outer Liner Assembly	
<b>7</b> B5013	-30	-40	-50	Gas Hose Assembly	
<b>8</b> B5012	-30	-40	-50	Water Inlet Hose Assembly	
<b>9</b> B5015	-30	-40	-50	Power Cable Assembly	
<b>10</b> B5010	-30	-40	-50	Switch Lead Assembly	
<b>13</b> B5019	-30	-40	-50	Canvas Cover Assembly	

# SB 501W EXT

## Water Cooled MIG Welding Torch

Rating: 520A CO2 430A mixed gas @ 100% duty cycle, EN60974-7. .040"-1/16"/1.0mm-1.6mm wires

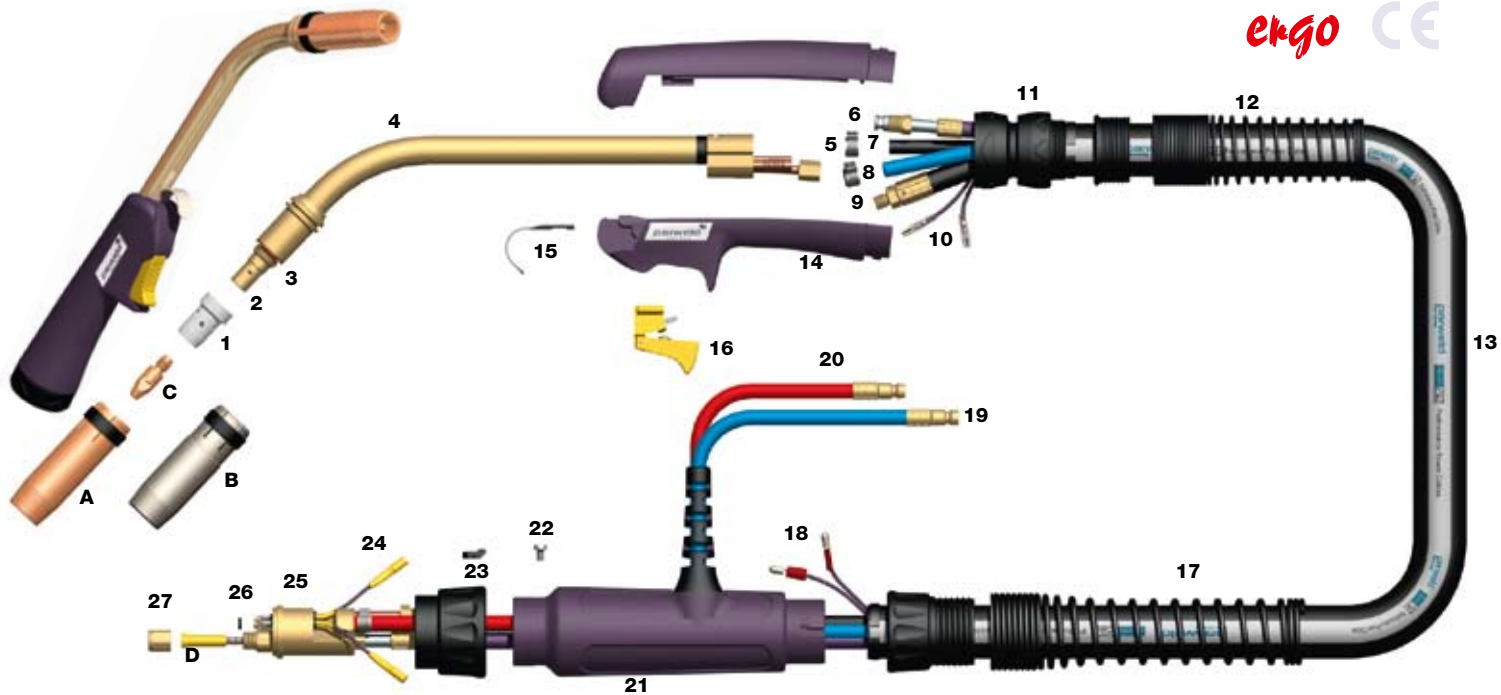

Model				
Stock Code	3M	4M	5M	Model Description
B500L	-30ER	-40ER	50ER	Welding Torch c/w Euro Fitting

Nozzles	
Stock Code	Description
<b>A</b> B5027	Cylindrical Nozzle 3/4"/19mm Bore
B5028*	Conical Nozzle 5/8"/16mm Bore
B5029	Tapered Nozzle 9/16"/14mm Bore
<b>B</b> 5028HD	Heavy Duty Conical Nozzle 5/8"/16mm Bore

Contact Tips	
Stock Code	Description
<b>C</b> B4014-10	Contact Tip .040"/1.0mm M8 Ecu
B4014-12*	Contact Tip .045"/1.2mm M8 Ecu
B4014-16	Contact Tip 1/16"/1.6mm M8 Ecu
B4015-10	Contact Tip .040"/1.0mm M8 CuCrZr
B4015-12	Contact Tip .045"/1.2mm M8 CuCrZr
B4015-16	Contact Tip 1/16"/1.6mm M8 CuCrZr

Liners	
Stock Code	Description
<b>D</b> B5033-30	Plain Liner .040"-.045"/1.0-1.2mm x 3mt
B5033-40	Plain Liner .040"-.045"/1.0-1.2mm x 4mt
B5033-50	Plain Liner .040"-.045"/1.0-1.2mm x 5mt
B5034-30*	Plain Liner .045"-1/16"/1.2-1.6mm x 3mt
B5034-40*	Plain Liner .045"-1/16"/1.2-1.6mm x 4mt
B5034-50*	Plain Liner .045"-1/16"/1.2-1.6mm x 5mt
B2513-30	Teflon Liner .040"-.045"/1.0-1.2mm x 3mt
B2513-40	Teflon Liner .040"-.045"/1.0-1.2mm x 4mt
B2513-50	Teflon Liner .040"-.045"/1.0-1.2mm x 5mt
B3626-30	Teflon Liner .045"-1/16"/1.0-1.2 x 3mt
B3626-40	Teflon Liner .045"-1/16"/1.0-1.2 x 4mt
B3626-50	Teflon Liner .045"-1/16"/1.0-1.2 x 5mt

Components		
Stock Code	Description	* Denotes Standard Build
<b>1</b> B5005B	Diffuser Black	
B5005C*	Diffuser Ceramic	
B5005W	Diffuser White	
<b>2</b> B5001	Tip Adaptor 25.0mm M8	
<b>3</b> B5003	Insulating Washer	
<b>4</b> B5002L	Extended Length Swan Neck	
<b>5</b> B5024	Water Hose Clamp 9.5mm	
<b>11</b> B8031	Ball Joint Assembly c/w Clamp	
<b>12</b> B8032	Spring Cable Support c/w Adaptor	
<b>14</b> B2514	Ergo Handle	
<b>15</b> B2517	Hanger Hook	
<b>16</b> B2516	Ergo Trigger	
<b>17</b> B8027	Cable Support	
<b>18</b> B1522	Cable Terminal Male	
<b>19</b> B5023	Water Hose Nipple	
<b>20</b> B5017	Water Outlet Hose O/Braid	
<b>21</b> B5022	Gun Plug Housing c/w Lock Nut and Hose Supports	
<b>22</b> B1526	Gun Plug Screw	
<b>23</b> B1519	Gun Plug Nut c/w Insert	
<b>24</b> Spring Pin 2	Spring Pin Assembly	
<b>25</b> B5098	Gun Plug Body c/w Spring Pins	
<b>26</b> B1524	Gun Plug 'O' Ring	
<b>27</b> B1525	Liner Nut	

Cable Assembly Components					
Stock Code	3M	4M	5M	Model Description	
<b>6</b> B5008	-30	-40	-50	Outer Liner Assembly	
<b>7</b> B5013	-30	-40	-50	Gas Hose Assembly	
<b>8</b> B5012	-30	-40	-50	Water Inlet Hose Assembly	
<b>9</b> B5015	-30	-40	-50	Power Cable Assembly	
<b>10</b> B5010	-30	-40	-50	Switch Lead Assembly	
<b>13</b> B5019	-30	-40	-50	Canvas Cover Assembly	

# SAB 360A

## Air Cooled Fume Extraction MIG / MAG Welding Torch

Rating: 300A CO2 270A mixed gas @ 60% duty cycle, EN60974-7. 0.8 to 1.2mm wires

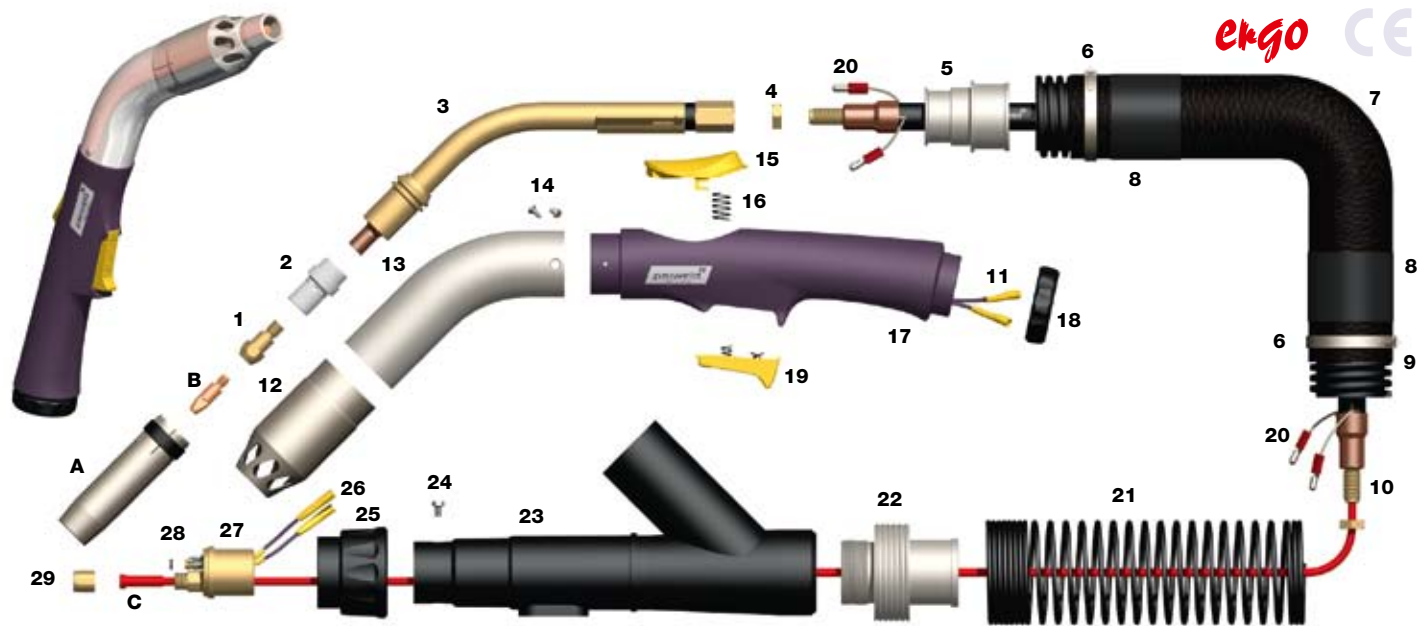

Model	3M	4M	5M	Model Description
Stock Code	3M	4M	5M	
SAB3600	-30ER	-40ER	-50ER	Fume Torch c/w Euro Fitting

Nozzles	
Stock Code	Description
<b>A</b> B3615	Cylindrical Nozzle 3/4"/19mm Bore
B3616*	Conical Nozzle 5/8"/16mm Bore
B3617	Tapered Nozzle 15/32"/12mm Bore

Contact Tips	
Stock Code	Description
<b>B</b> B2504-10	Contact Tip .040"/1.0mm M6 Ecu
B2504-12*	Contact Tip .045"/1.2mm M6 Ecu
B2505-10	Contact Tip .040"/1.0mm M6 CuCrZr
B2505-12	Contact Tip .045"/1.2mm M6 CuCrZr
B4014-10	Contact Tip .040"/1.0mm M8 Ecu
B4014-12	Contact Tip .045"/1.2mm M8 Ecu
B4015-10	Contact Tip .040"/1.0mm M8 CuCrZr
B4015-12	Contact Tip .045"/1.2mm M8 CuCrZr

Liners	
Stock Code	Description
<b>C</b> B2524-30*	Steel Liner .040"- .045"/1.0-1.2mm x 3mt
B2524-40*	Steel Liner .040"- .045"/1.0-1.2mm x 4mt
B2524-50*	Steel Liner .040"- .045"/1.0-1.2mm x 5mt
B2513-30	Teflon Liner .040"- .045"/1.0-1.2mm x 3mt
B2513-40	Teflon Liner .040"- .045"/1.0-1.2mm x 4mt
B2513-50	Teflon Liner .040"- .045"/1.0-1.2mm x 5mt

Components	
Stock Code	Description
<b>1</b> B3612*	Tip Adaptor 28.5mm M6
B3613	Tip Adaptor 31.5mm M6
B3614	Tip Adaptor 28.5mm M8
<b>2</b> B3605C*	Diffuser Ceramic

Components continued		
Stock Code	Description	* Denotes Standard Build
<b>3</b> SAB3603	Swan Neck	
<b>4</b> B1505	Lock Nut	
<b>5</b> SAB0019	Swivel Connector	
<b>6</b> SAB0024	Hose Clamp	
<b>7</b> SAB0016-30	Fume Hose Sleeve x 3mt	
SAB0016-40	Fume Hose Sleeve x 4mt	
SAB0016-50	Fume Hose Sleeve x 5mt	
<b>8</b> SAB0049	Heatshrink	
<b>9</b> SAB0045-30	Flexible Hose x 3mt	
SAB0045-40	Flexible Hose x 4mt	
SAB0045-50	Flexible Hose x 5mt	
<b>10</b> B3609-30	Hyperflex Cable Assembly x 3mt	
B3609-40	Hyperflex Cable Assembly x 4mt	
B3609-50	Hyperflex Cable Assembly x 5mt	
<b>11</b> SAB1829	Switch Wire Locating Pins	
<b>12</b> SAB3693	Fume Nozzle	
<b>13</b> SAB3692	Front Extraction Chamber	
<b>14</b> SAB0010	Chamber Fixing Screw	
<b>15</b> SAB2518	Yellow Vent	
<b>16</b> SAB2519	Vent Spring	
<b>17</b> SAB2514	Handle	
<b>18</b> SAB8005	Handle Lock Nut	
<b>19</b> SAB2516	Trigger	
<b>20</b> B1522	Cable Terminal Male	
<b>21</b> SAB0063	Spring Cable Support	
<b>22</b> SAB5025	Extraction Chamber Connector	
<b>23</b> SAB5022	Rear Extraction Chamber	
<b>24</b> B1526	Gun Plug Screw	
<b>25</b> B1519/BK	Gun Plug Nut c/w Insert	
<b>26</b> Spring Pin 2	Spring Pin Assembly	
<b>27</b> B1528	Gun Plug Body c/w Spring Pins	
<b>28</b> B1524	Gun Plug 'O' Ring	
<b>29</b> B1525	Liner Nut	

# SB 250A AUTO

## Air Cooled Automatic MIG Welding Torch

Rating: 230A CO<sub>2</sub> 200A mixed gas @ 60% duty cycle, EN60974-7. .030"-.045"/0.8mm-1.2mm wires

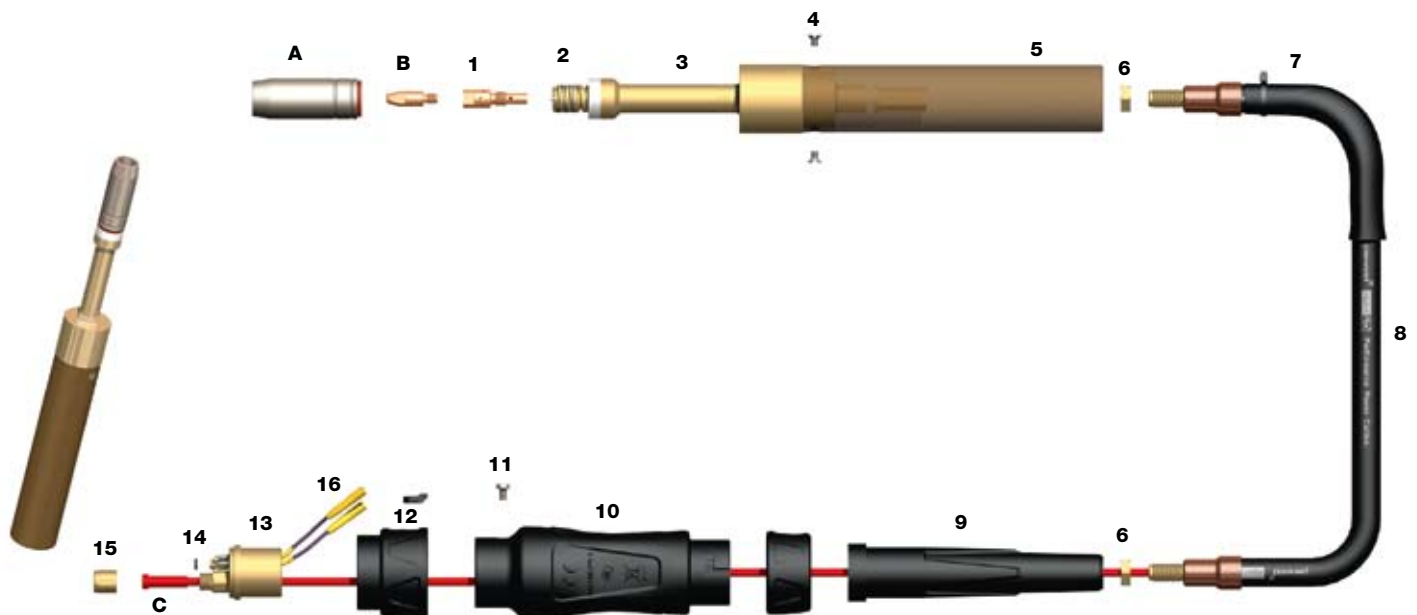

Model				
Stock Code	2M	3M	4M	Model Description
B2500	-20A	-30A	-40A	Welding Torch c/w Euro Fitting

Nozzles	
Stock Code	Description
<b>A</b> B2507	Cylindrical Nozzle 1 1/16"/18mm Bore
B2508*	Conical Nozzle 19/32"/15mm Bore
B2509	Tapered Nozzle 15/32"/12mm Bore
B2510	Bottle Nozzle 19/32"/15mm Bore
B2511	Spot Welding Nozzle 1 1/16"/18mm Bore

Contact Tips	
Stock Code	Description
<b>B</b> B2504-08	Contact Tip .030"/0.8mm M6 Ecu
B2504-09	Contact Tip .035"/0.9mm M6 Ecu
B2504-10*	Contact Tip .040"/1.0mm M6 Ecu
B2504-12	Contact Tip .045"/1.2mm M6 Ecu
B2505-08	Contact Tip .030"/0.8mm M6 CuCrZr
B2505-09	Contact Tip .035"/0.9mm M6 CuCrZr
B2505-10	Contact Tip .040"/1.0mm M6 CuCrZr
B2505-12	Contact Tip .045"/1.2mm M6 CuCrZr

Liners	
Stock Code	Description
<b>C</b> B1535-30	Steel Liner .030"-.035"/0.6-0.9mm x 3mt
B1535-40	Steel Liner .030"-.035"/0.6-0.9mm x 4mt
B2524-30*	Steel Liner .040"-.045"/1.0-1.2mm x 3mt
B2524-40*	Steel Liner .040"-.045"/1.0-1.2mm x 4mt
B1536-30	Teflon Liner .030"-.035"/0.6-0.9mm x 3mt
B1536-40	Teflon Liner .030"-.035"/0.6-0.9mm x 4mt
B2513-30	Teflon Liner .040"-.045"/1.0-1.2mm x 3mt
B2513-40	Teflon Liner .040"-.045"/1.0-1.2mm x 4mt

Components		
Stock Code	Description	* Denotes Standard Build
<b>1</b> B2506*	Tip Adaptor M6	
<b>NI</b> B2536	Tip Adaptor M8 – See M8 Tips shown on Page 31	
<b>2</b> B2502	Shroud Spring	
<b>3</b> B2520	Auto Straight Neck	
<b>4</b> B3629	Handle Screw	
<b>5</b> B3630	Automatic Handle	
<b>6</b> B1505	Lock Nut	
<b>7</b> B3660	Cable Support	
<b>8</b> B2503-20	Hyperflex Cable Assembly X 2mt	
B2503-30	Hyperflex Cable Assembly x 3mt	
B2503-40	Hyperflex Cable Assembly x 4mt	
<b>9</b> B2841	Cable Support	
<b>10</b> B1518/BK	Gun Plug Housing c/w Nut (Black)	
<b>11</b> B1526	Gun Plug Screw (Black)	
<b>12</b> B1519/BK	Gun Plug Nut c/w Insert (Black)	
<b>13</b> B1528	Gun Plug Body c/w Spring Pins	
<b>14</b> B1524	Gun Plug 'O' Ring	
<b>15</b> B1525	Liner Nut	
<b>16</b> Spring Pin 2	Spring Pin Assembly	

NI Not Illustrated.

# SB 360A AUTO

## Air Cooled Automatic MIG Welding Torch

Rating: 300A CO<sub>2</sub> 270A mixed gas @ 60% duty cycle, EN60974-7. .030"-.045"/1.0mm-1.2mm wires

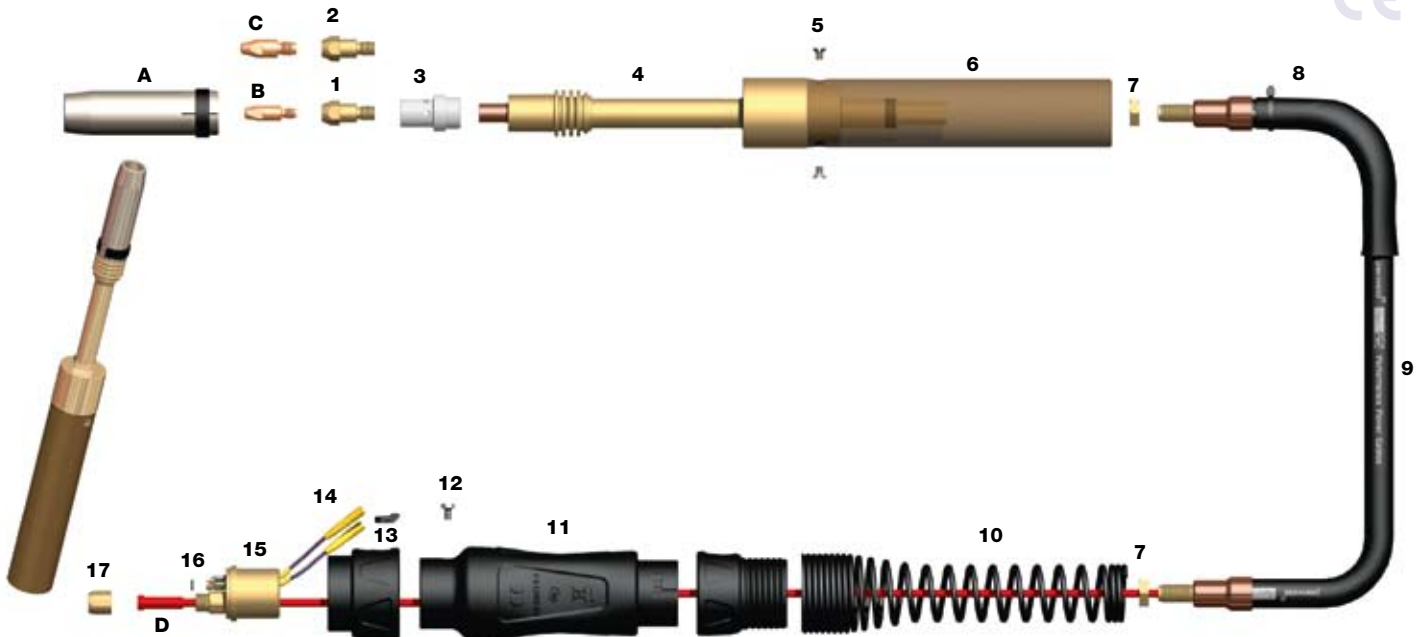

Model				
Stock Code	2M	3M	4M	Model Description
B3600	-20A	-30A	-40A	Welding Torch c/w Euro Fitting

Nozzles	
Stock Code	Description
<b>A</b> B3615	Cylindrical Nozzle 3/4"/19mm Bore
B3616*	Conical Nozzle 5/8"/16mm Bore
B3617	Tapered Nozzle 15/32"/12mm Bore

Contact Tips	
Stock Code	Description
<b>B</b> B2504-10	Contact Tip .040"/1.0mm M6 Ecu
B2504-12*	Contact Tip .045"/1.2mm M6 Ecu
B2505-10	Contact Tip .040"/1.0mm M6 CuCrZr
B2505-12	Contact Tip .045"/1.2mm M6 CuCrZr
<b>C</b> B4014-10	Contact Tip .040"/1.0mm M8 Ecu
B4014-12	Contact Tip .045"/1.2mm M8 Ecu
B4015-10	Contact Tip .040"/1.0mm M8 CuCrZr
B4015-12	Contact Tip .045"/1.2mm M8 CuCrZr

Liners	
Stock Code	Description
<b>D</b> B2524-30*	Steel Liner .040"-.045"/1.0-1.2mm x 3mt
B2524-40*	Steel Liner .040"-.045"/1.0-1.2mm x 4mt
B2513-30	Teflon Liner .040"-.045"/1.0-1.2mm x 3mt
B2513-40	Teflon Liner .040"-.045"/1.0-1.2mm x 4mt

Components		
Stock Code	Description	* Denotes Standard Build
<b>1</b> B3612*	Tip Adaptor 28.5mm M6	
<b>2</b> B3614	Tip Adaptor 28.5mm M8	
<b>NI</b> B3613	Tip Adaptor 31.5mm M6	
<b>3</b> B3605B	Diffuser Black	
B3605C*	Diffuser Ceramic	
B3605W	Diffuser White	
<b>4</b> B3627	Auto Straight Neck	
<b>5</b> B3629	Handle Screw	
<b>6</b> B3630	Automatic Handle	
<b>7</b> B1505	Lock Nut	
<b>8</b> B3660	Cable Support	
<b>9</b> B3609-20	Hyperflex Cable Assembly x 2mt	
B3609-30	Hyperflex Cable Assembly x 3mt	
B3609-40	Hyperflex Cable Assembly x 4mt	
<b>10</b> B8026	Spring Cable Support	
<b>11</b> B1518/BK	Gun Plug Housing c/w Nut (Black)	
<b>12</b> B1526	Gun Plug Screw	
<b>13</b> B1519/BK	Gun Plug Nut c/w Insert (Black)	
<b>14</b> Spring Pin 2	Spring Pin Assembly	
<b>15</b> B1528	Gun Plug Body c/w Spring Pins	
<b>16</b> B1524	Gun Plug 'O' Ring	
<b>17</b> B1525	Liner Nut	

NI Not Illustrated.

# SB 501W AUTO

## Water Cooled Automatic MIG Welding Torch

Rating: 520A CO2 430A mixed gas @ 100% duty cycle, EN60974-7. .040"-1/16"/1.0mm-1.6mm wires

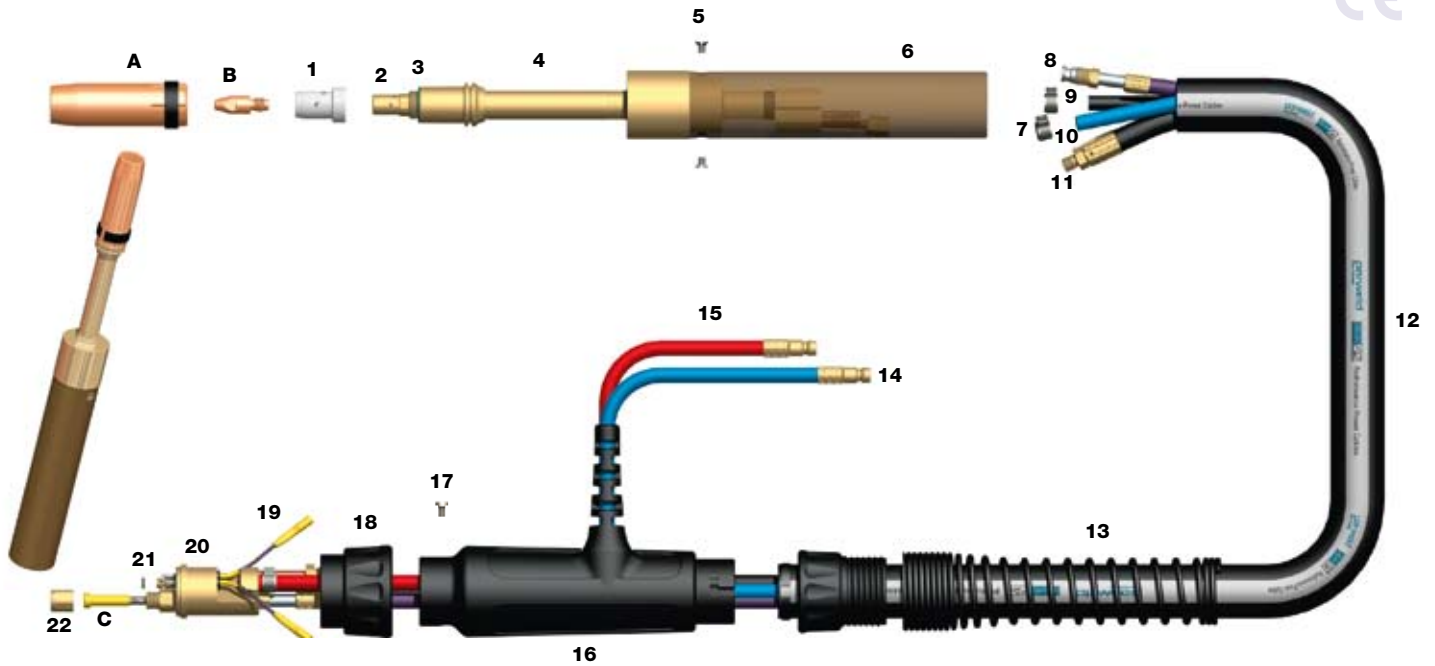

Model				
Stock Code	2M	3M	4M	Model Description
B5000	-20A	-30A	-40A	Welding Torch c/w Euro Fitting

Nozzles	
Stock Code	Description
<b>A</b> B5027	Cylindrical Nozzle 3/4"/19mm Bore
B5028*	Conical Nozzle 5/8"/16mm Bore
B5029	Tapered Nozzle 9/16"/14mm Bore

Contact Tips	
Stock Code	Description
<b>B</b> B4014-10	Contact Tip .040"/1.0mm M8 Ecu
B4014-12*	Contact Tip .045"/1.2mm M8 Ecu
B4014-16	Contact Tip 1/16"/1.6mm M8 Ecu
B4015-10	Contact Tip .040"/1.0mm M8 CuCrZr
B4015-12	Contact Tip .045"/1.2mm M8 CuCrZr
B4015-16	Contact Tip 1/16"/1.6mm M8 CuCrZr

Liners	
Stock Code	Description
<b>C</b> B5033-30	Plain Liner .040"- .045"/1.0-1.2mm x 3mt
B5033-40	Plain Liner .040"- .045"/1.0-1.2mm x 4mt
B5034-30*	Plain Liner .045"-1/16"/1.2-1.6mm x 3mt
B5034-40*	Plain Liner .045"-1/16"/1.2-1.6mm x 4mt
B4033-30	Plain Liner .080"- .090"/2.0-2.4mm x 3mt
B4033-40	Plain Liner .080"- .090"/2.0-2.4mm x 4mt
B2513-30	Teflon Liner .040"- .045"/1.0-1.2mm x 3mt
B2513-40	Teflon Liner .040"- .045"/1.0-1.2mm x 4mt
B3626-30	Teflon Liner .045"-1/16"/1.2mm-1.6mm x 3mt
B3626-40	Teflon Liner .045"-1/16"/1.2mm-1.6mm x 4mt

Components		
Stock Code	Description	* Denotes Standard Build
<b>1</b> B5005B	Diffuser Black	
B5005C*	Diffuser Ceramic	
B5005W	Diffuser White	
<b>2</b> B5001	Tip Adaptor 25.0mm M8	
<b>3</b> B5003	Insulating Washer	
<b>4</b> B5002A	Auto Straight Neck	
<b>5</b> B3629	Handle Screw	
<b>6</b> B3630	Automatic Handle	
<b>7</b> B5024	Water Hose Clamp 9.5mm	
<b>13</b> B8027	Spring Cable Support	
<b>14</b> B5023	Water Hose Nipple	
<b>15</b> B5017	Water Outlet Hose O/Braid	
<b>16</b> B5022/BK	Gun Plug Housing (Black) c/w Lock Nut and Hose Supports	
<b>17</b> B1526	Gun Plug Screw (Black)	
<b>18</b> B1519/BK	Gun Plug Nut c/w Insert (Black)	
<b>19</b> Spring Pin 2	Spring Pin Assembly	
<b>20</b> B5098	Gun Plug Body c/w Spring Pins	
<b>21</b> B1524	Gun Plug 'O' Ring	
<b>22</b> B1525	Liner Nut	

Cable Assembly					
Stock Code	2M	3M	4M	Model Description	
<b>8</b> B5008	-20	-30	-40	Outer Liner Assembly	
<b>9</b> B5013	-20	-30	-40	Gas Hose Assembly	
<b>10</b> B5012	-20	-30	-40	Water Inlet Hose Assembly	
<b>11</b> B5015	-20	-30	-40	Power Cable Assembly	
<b>12</b> B5019	-20	-30	-40	Canvas Cable Assembly	

# PP 360A

## Air Cooled MIG Welding Torch

Rating: 300A CO2 270A mixed gas @ 60% duty cycle, EN60974-7. .030"-.045"/0.8mm-1.2mm wires

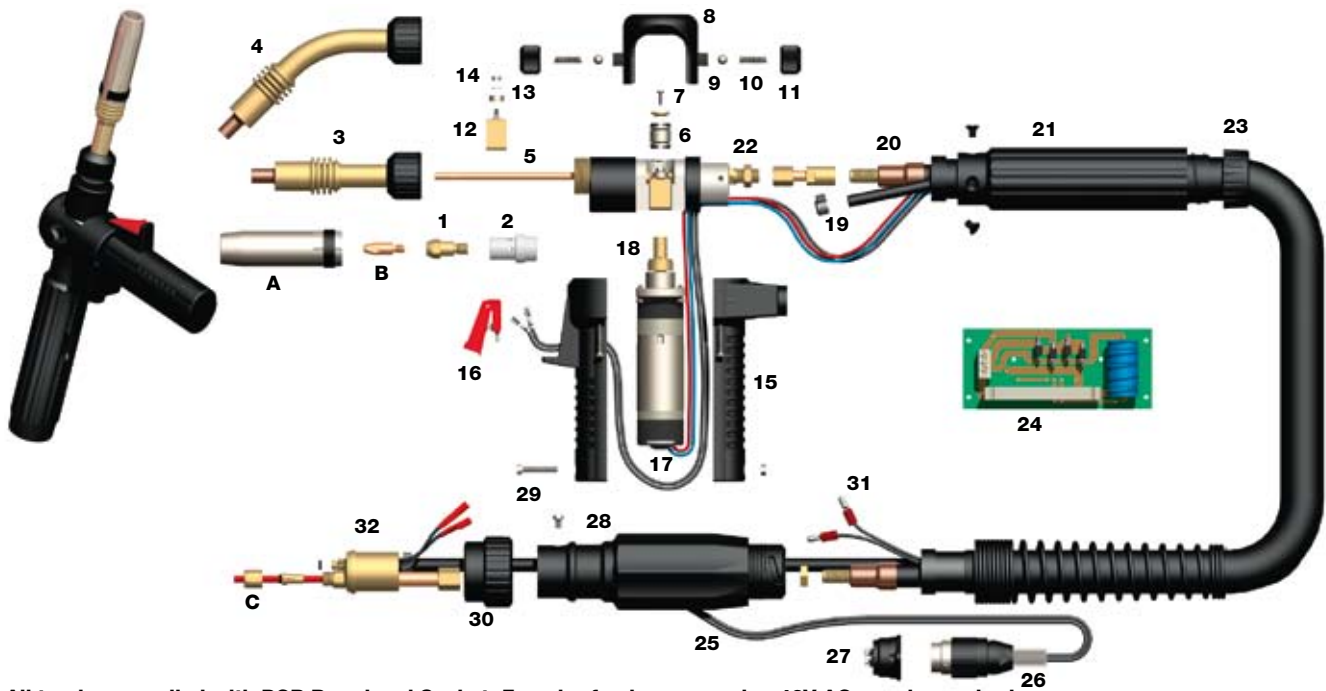

All torches supplied with PCB Board and Socket. For wire feeder conversion 42V AC supply required.

Model	Stock Code	8M	Model Description
PP3600A	-80		180° Neck Push Pull Welding Torch c/w Euro Fitting
PP3645A	-80		45° Neck Push Pull Welding Torch c/w Euro Fitting

Nozzles	
Stock Code	Description
<b>A</b> B3615	Cylindrical Nozzle 3/4"/19mm Bore
B3616*	Conical Nozzle 5/8"/19mm Bore
B3617	Tapered Nozzle 15/32"/19mm Bore

Contact Tips	
Stock Code	Description
<b>B</b> B2504-09	Contact Tip .035"/0.9mm M6 Ecu
B2504-10	Contact Tip .040"/1.0mm M6 Ecu
B2504-12*	Contact Tip .045"/1.2mm M6 Ecu

Liners	
Stock Code	Description
<b>C</b> B1536-80	Teflon Liner .035"-.040"/0.6-0.9mm x 8mt
B2513-80	Teflon Liner .040"-.045"/1.0-1.2mm x 8mt
B3626-80	Teflon Liner .045"-1/16"/1.2mm-1.6mm X 8mt

Components		
Stock Code	Description	* Denotes Standard Build
<b>1</b> B3612	Tip Adaptor 28.5mm M6	
<b>2</b> B3605B	Diffuser Black	
B3605C	Diffuser Ceramic	
B3605W*	Diffuser White	
<b>3</b> B3638	Straight Neck	
<b>4</b> B3638-45	Swan Neck 45°	
<b>5</b> B3662	Contact Tube	
<b>6</b> B3656-08	Drive Roll 0.8mm	
B3656-08A	Drive Roll 0.8mm Aluminium	
B3656-10	Drive Roll 1.0mm	
B3656-10A	Drive Roll 1.0mm Aluminium	

Components continued	
Stock Code	Description
B3656-12	Drive Roll 1.2mm
B3656-12A*	Drive Roll 1.2mm Aluminium
B3656-16	Drive Roll 1.6mm
B3656-16A	Drive Roll 1.6mm Aluminium
<b>7</b> B3649	Assorted Screw & Nut Pack
<b>8</b> B3644	Snap On Head
<b>9</b> B3645	Ball Bearing
<b>10</b> B3646	Spring
<b>11</b> B3647	Spring Cap
<b>12</b> B3640	Pressure Arm
<b>13</b> B3641	Pressure Roll
<b>14</b> B3657	Retaining Washer
<b>15</b> B3648T	Pair Of Handles
<b>16</b> B1408/PP	Bladeswitch Trigger
<b>17</b> B3654	Motor 42V
<b>18</b> B3655	Seating
<b>19</b> B5013-80	Gas Hose Assembly x 8mt
<b>20</b> B3673	Power Cable Assembly x 8mt
<b>21</b> B3661	Cable Support
<b>22</b> B3675	Power Cable Adaptor
<b>23</b> B5035	Cable Support Nut
<b>24</b> B3667	Printed Circuit Board 42 Volt
<b>25</b> B3663-85	Control Cable Assembly x 8mt
<b>26</b> B3674	5 Pin Plug
<b>27</b> B3672	Socket For Push Pull Plug
<b>28</b> B5022/BK	Gun Plug Housing
<b>29</b> B1526	Gun Plug Screw
<b>30</b> B1519/BK	Gun Plug Nut – Black
<b>31</b> B1523	Gun Plug Terminal
<b>32</b> B3666	Gun Plug Body

# PP 400W

## Water Cooled MIG Welding Torch

Rating: 400A CO2 350A mixed gas, EN60974-7 @ 100% duty cycle. .030"-.045"/0.8mm-1.2mm wires

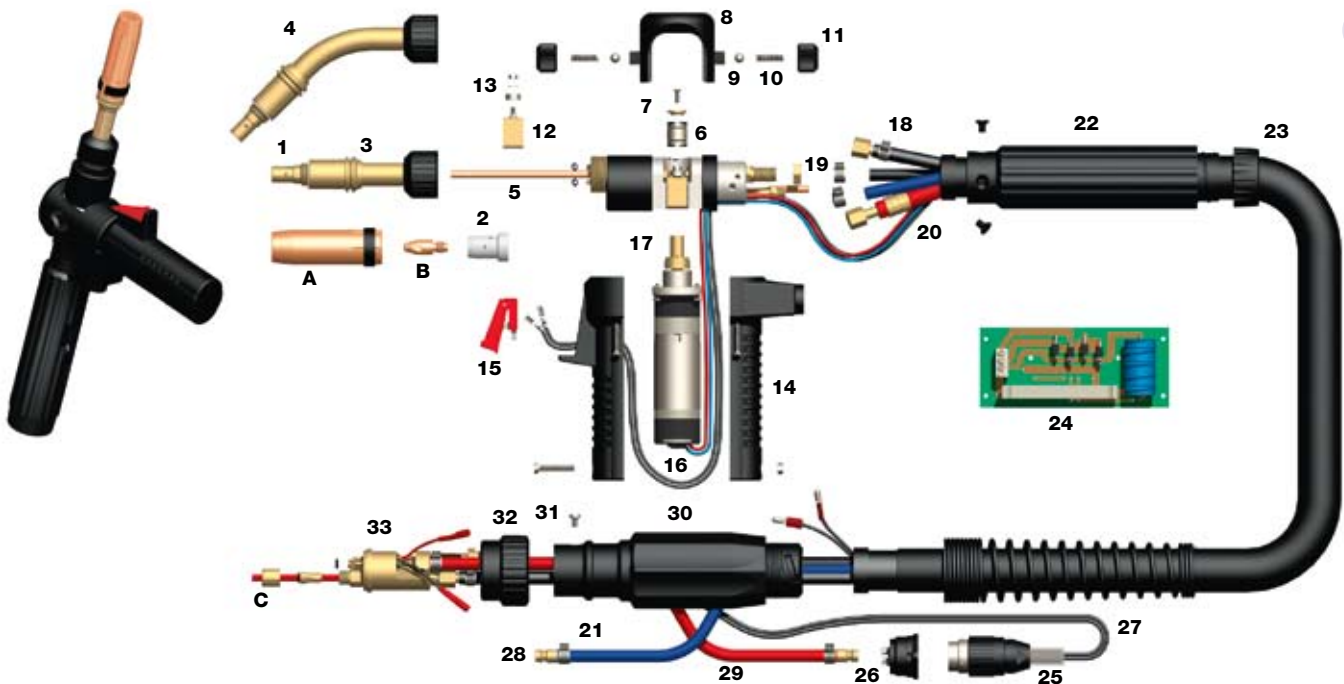

All torches supplied with PCB Board and Socket. For wire feeder conversion 42V AC supply required.

Model		
Stock Code	8M	Model Description
PP4000W	-80	180° Neck Push Pull Welding Torch c/w Euro Fitting
PP4045W	-80	45° Neck Push Pull Welding Torch c/w Euro Fitting

Nozzles		
Stock Code	Description	
A B5027	Cylindrical Nozzle 3/4"/19mm Bore	
B5028*	Conical Nozzle 5/8"/16mm Bore	
B5029	Tapered Nozzle 9/16"/14mm Bore	

Contact Tips		
Stock Code	Description	
B B4014-10	Contact Tip .040"/1.0mm M8 Ecu	
B4014-12*	Contact Tip .045"/1.2mm M8 Ecu	
B4014-16	Contact Tip 1/16"/1.6mm M8 Ecu	

Liners		
Stock Code	Description	
C B2513-80	Teflon Liner .040"-.045"/1.0-1.2mm x 8mt	
B3626-80	Teflon Liner .045"-1/16"/1.2mm-1.6mm x 8mt	

Components		
Stock Code	Description	* Denotes Standard Build
1 B5001	Tip Adaptor 25.0mm M8	
2 B5005B	Diffuser Black	
B5005C	Diffuser Ceramic	
3 B4051	Straight Neck	
4 B4051-45	Swan Neck	
5 B3662	Contact Tube	
6 B3656-10	Drive Roll 1.0mm	
B3656-10A	Drive Roll 1.0mm Aluminium	
B3656-12	Drive Roll 1.2mm	
B3656-12A*	Drive Roll 1.2mm Aluminium	
B3657	Retaining Washer	
7 B3649	Assorted Screw & Nut Pack	

Components continued		
Stock Code	Description	
8 B3644	Snap On Head	
9 B3645	Ball Bearing	
10 B3646	Spring	
11 B3647	Spring Cap	
12 B3640	Pressure Arm	
13 B3641	Pressure Roll	
14 B3648T	Pair Of Handles	
15 B1408/PP	Bladeswitch Trigger	
16 B3654	Motor 42V	
17 B3655	Seating	
18 B5008-80	Outer Liner Assembly x 8mt	
19 B5013-80	Gas Hose Assembly x 8mt	
20 B4048-80	Power Cable Assembly x 8mt	
21 B5012-80	Water Inlet Hose Assy x 8mt	
22 B3661	Cable Support	
23 B5035	Cable Support Nut	
24 B3667	Printed Circuit Board 42 Volt	
25 B3674	5 Pin Plug	
26 B3672	Socket For Push Pull Plug	
27 B3663-85	Control Cable Assy x 8mt	
28 B5023	Water Hose Nipple	
29 B5017	Water Outlet Hose O/Braid	
30 B5022/BK	Gun Plug Housing	
31 B1526	Gun Plug Screw	
32 B1519/BK	Gun Plug Nut - Black	
33 B5098	Gun Plug Body c/w Spring Pins	

# Alternative Handles

## Microswitch



Suitable for models:  
SB150A, 240A, 250A, 260A, 360A, 240W, 350W, 401W, 501W

Components	
Stock Code	Description
1 B1508	Microswitch Handle Kit
B1510	Microswitch Trigger

## Bladeswitch



Suitable for models:  
SB150A, 240A, 250A, 260A, 360A, 240W, 350W, 401W, 501W

Components	
Stock Code	Description
2 B1509	Bladeswitch Handle Kit, Air Cooled
NI B1509/W	Bladeswitch Handle Kit, Water Cooled
B1408/B	Bladeswitch Trigger

## Small *ekgo*



Suitable for models:  
SB120A, 140A, 230A

Components	
Stock Code	Description
3 B1414	Ergo Handle Kit
B1416	Ergo Trigger Small

## Medium *ekgo*



Suitable for models:  
SB150A, 240A, 250A, 260A, 360A, 240W, 350W, 401W, 501W

Components	
Stock Code	Description
4 B2514	Ergo Handle Kit
B2516	Ergo Trigger

## Large *ekgo*



Suitable for models:  
SB380A, 400A

Components	
Stock Code	Description
5 B4514	Ergo Handle Kit
B2516	Ergo Trigger